

TECHNICAL MANUAL

METAL CEILINGS



Emerging from the Technical Working Group of Industrial Metal Ceiling Manufacturers, this association has defined internationally recognized quality standards for metal ceilings since its foundation in 1988 and has continuously updated it to the state of the art.

Primary objective of the TAIM e. V. is the promotion of the quality and quality aspect of metal ceiling systems beyond the minimum requirements of European standards. TAIM sets new values for existing standards that do not or only partially cover them through the additional development of requirements for metal ceilings.

Publisher:
TAIM e.V. – Association of Industrial Metal Ceiling Manufacturers

Osloer Str. 100
13359 Berlin
E-Mail: taim.mail@t-online.de
Website: www.taim.info

Contents

1	Foreword	7
2	Scope	8
3	Normative references	9
4	TAIM – certification procedure	11
5	TAIM -compliant metal ceiling systems	11
6	Terms and definitions	11
6.1	Metal ceiling system	11
6.1.1	Hook-on systems.....	13
6.1.2	Clip-in systems	13
6.1.3	Post-cap systems	14
6.1.4	Tile ceiling system	16
6.1.5	Lay-in- / Lay-on systems.....	16
6.1.6	Swing-down systems.....	17
6.1.7	Inspection hatches.....	18
6.1.8	Ceiling islands	19
6.1.9	Double-walled baffle systems	20
6.1.10	Single-walled baffle systems	21
6.1.11	Linear panel systems.....	21
6.1.12	Open cell systems	22
6.1.13	Expanded metal ceiling systems.....	23
6.1.14	Composite elements.....	24
6.2	Heating and cooling ceiling systems	25
6.2.1	Heating-/cooling medium	25
6.2.2	Active and passive elements	26
6.2.3	Tubing	27
6.2.4	Heat conducting profile	28
6.2.5	Meander	28
6.2.6	Meander in thermally conductive inserts.....	29
6.2.7	Capillary tube mats.....	29
6.2.8	Connection and distribution conductions	30
6.2.9	Plug in connectors	30
6.2.10	Heating- or cooling fields	30
6.2.11	Control area.....	30
6.3	Metal ceiling membrane.....	31
6.3.1	Functional upstands	31
6.3.2	Stabilization upstands.....	31
6.3.3	Membrane upstands.....	32

6.3.4	Joint types	34
6.3.5	Ropes as operating and assembly aid	35
6.4	Substructure	35
6.4.1	Profiles	36
6.4.2	Suspension.....	38
6.4.3	Top fixing.....	39
6.4.4	Suspension height.....	39
6.4.5	Connector.....	39
6.4.6	Primary grid.....	39
6.4.7	Secondary grid/carrier profiles.....	39
6.5	Perimeter trims	40
6.5.1	Load bearing perimeter trim.....	40
6.5.2	Non load-bearing perimeter trim	40
6.6	Perforations	41
6.7	Axial dimension.....	41
6.8	Module dimension of membrane.....	41
6.9	Durability range - Corrosion protection.....	42
6.10	Responsible / Participants	42
6.10.1	Building designer.....	42
6.10.2	Installation company.....	42
6.10.3	System manufacturer	42
7	Requirements on metal ceiling systems	43
7.1	Mechanical strength.....	44
7.1.1	Fixing to the structure	44
7.1.2	Substructure	44
7.1.3	Flexural tensile strength.....	44
7.1.4	Connection of partitions	45
7.1.5	Expansion joints	45
7.1.6	Built-in and built-on elements	45
7.1.7	Lay-in or lay-on elements	45
7.1.8	Cutouts.....	46
7.1.9	Wind load resistance	46
7.1.10	Impact resistance	47
7.1.11	Built-in or built-on components	48
7.1.12	Seismic resistance.....	49
7.2	Materials.....	49
7.3	Dimensions and tolerances for membranes	50
7.3.1	Metal membranes and tiles.....	51

7.3.2	Linear panels and single-walled baffles	52
7.3.3	Expanded metal ceilings.....	54
7.3.4	Baffle ceilings	55
7.3.5	Open cell ceilings	55
7.4	Safety in case of fire	56
7.4.1	Reaction to fire	56
7.4.2	Fire resistance.....	56
7.4.3	Smoke leakage.....	56
7.5	Heated and cooling ceiling systems	57
7.6	Electrical safety.....	57
7.7	Hygiene, health and environment – Toxic gasses and dangerous substances.....	57
7.7.1	Hygiene	57
7.7.2	VOC – Volatile organic compounds	58
7.7.3	Susceptibility to the growth of harmful micro-organisms	58
7.8	Acoustics	59
7.8.1	Airborne sound insulation	59
7.8.2	Sound absorption	59
7.9	Durability - Corrosion protection.....	60
7.9.1	Corrosivity categories / Exposure classes	60
7.9.2	Durability range	62
7.9.3	Testing procedure.....	62
7.9.4	Test specimen	65
7.9.5	Assessment of corrosion protection systems	65
7.10	Coatings	66
7.10.1	Coating processes.....	66
7.10.2	Coating thickness	67
7.10.3	Colours / Colour deviations.....	67
7.10.4	Gloss.....	68
7.10.5	Light reflectance	68
7.10.6	Perforations.....	68
7.10.7	Surfaces with protective film	70
8	Test methods	71
8.1	Geometric properties	71
8.1.1	Length and width dimensions	71
8.1.2	Upstands	71
8.1.3	Deflection	72
8.1.4	Camber of linear panels.....	73
8.1.5	Squareness of membranes.....	73

8.2	Corrosion protection	74
8.3	Visual assessment of the surface	75
9	Declaration of performance and CE marking.....	77
9.1	Declaration of performance (DoP)	77
9.2	CE-Marking.....	79
10	Environmental Product Declarations	82
11	Packing, transport and storage	82
12	Installation.....	82
12.1	General.....	82
12.2	Installation instructions.....	83
12.2.1	Requirement of structural parts.....	83
12.2.2	Flatness tolerances	83
12.2.3	Installation sequence.....	83
12.2.4	Alignment	83
12.2.5	Absence of twisting.....	83
12.2.6	Alignment of the substructure	83
12.2.7	Built-ins, built-ons, add-ons	83
12.3	Surfaces	84
12.3.1	Batch dependency.....	84
12.3.2	Directionality.....	84
12.4	Special features of linear panels	84
12.4.1	Flatness at the perimeter	84
12.4.2	Linear panel connections.....	84
12.4.3	Squareness, thermal expansion, additional loads, special areas	84
13	Maintenance and operation.....	85
13.1	Service life requirements (maintenance).....	85
13.2	Cleaning	86
14	Recycling.....	86
15	National annex Germany	87
15.1	Smoke leakage.....	87
16	Technical terms English - German	88
17	Revision history	89

1 Foreword

Whether it is a new building or a refurbishment, construction products that are designed for health, safe use and sustainability are a must in every modern building.

Metal ceiling systems are considered sustainable building products which are particularly distinguished by their positive environmental and health-relevant characteristics. Aesthetic, economic and technological durability as well as architectural freedom of design are among the most important positive qualities.

Its ease of maintenance allows a durable, flexible and economic use of buildings. A high degree of prefabrication on an industrial basis, with a corresponding level of quality, enormous resistance to mechanical influences and the highly respected long product life cycle are important plus factors.

Members of the TAIM e.V. undertake in all points of the TMMC "Technical Manual for Metal Ceiling Systems" to comply with the specified minimum quality level, which goes beyond the normative requirements depending on the degree of utilization. The TAIM members demonstrate through the TAIM certification procedure that the quality requirements according to TAIM are met.

Only members of TAIM e.V. are entitled to use the brand name and logo.



The TMMC is intended for users who have general building expertise. It is assumed that users of the TMMC are familiar with the general technical regulations and standards.

This TMMC cannot handle all details and does not free users from complying with national regulations. All information is given to the best of our knowledge, but without guarantee of the TAIM e.V. The technical descriptions of the system manufacturers are binding.

This TMMC is constantly being supplemented and developed in line with technical progress. The editorial team is grateful for suggestions and constructive criticism and always endeavors to take them into account.

The current version is published at www.taim.info.

2 Scope

The "TMMC - Technical Manual Metal Ceiling Systems" provides the basics which are to be considered for the planning and the use of metal ceiling systems as well as cladding elements of metal and their composites according to TAIM.

This guide is meant to be of assistance to metal ceiling systems, but does not fully reflect all existing national and European directives, regulations and standards.

In this TMMC, "requirements, test methods and terms related to metal ceiling systems" are treated more succinctly than e.g. in various European standards as well as in the harmonized EN 13964 "Suspended ceilings - requirements and test methods" applicable to all ceiling systems.

The provisions of the TMMC are private law agreements and define the quality and state of the art of metal ceiling systems falling within the scope of application described therein.

Examples of typical applications:

- Office and administrative buildings
- Airports, train stations, schools, hospitals
- Shops, shopping malls, meeting places
- Sports halls, swimming pools
- Work shops, factories with production areas, laboratories
- Residential- and hotel areas

The TMMC

- ➔ applies to factory-made, industrially produced modular ceiling systems made of metal and composite materials with and without edge upstands which are placed on the market with the appropriate substructure components, individually or as a kit, optionally also with inlays and lay-on pads and/or installed items from system-compatible components.
- ➔ regulates requirements and test methods for complete metal ceiling systems in interior and exterior which are horizontally installed.
For inclined or curved surfaces, additional requirements shall be specified by the building designer.
- ➔ contains information for the various properties, for the design, manufacture, definition and selection of metal ceiling systems.

3 Normative references

Standard-No.	Title
EN ISO 354	Acoustics - Measurement of sound absorption in a reverberation room
DIN 971-1	Fasteners – Stud bolts – Part 1: Metric thread
EN 1264-4	Water based surface embedded heating and cooling systems – Part 4: Installation
EN 1396	Aluminium and aluminium alloys - Coil coated sheet and strip for general applications - Specifications
EN ISO 1461	Hot dip galvanized coatings on fabricated iron and steel articles - Specifications and test methods
EN 1991-1-4	Eurocode 1: Actions on structures - Part 1-4: General actions - Wind actions
EN 1993-1-4	Eurocode 3 - Design of steel structures - Part 1-4: General rules - Supplementary rules for stainless steels
EN 1998-1	Eurocode 8: Design of structures for earthquake resistance- Part 1: General rules, seismic actions and rules for buildings
EN ISO 2081	Metallic and other inorganic coatings – Electroplated coatings of zinc with supplementary treatments on iron or steel
EN ISO 2409	Paints and varnishes - Cross-cut test
EN ISO 2808	Paints and varnishes - Determination of film thickness
EN ISO 2813	Paints and varnishes - Determination of gloss value at 20°, 60° and 85°
EN ISO 4628ff	Paints and varnishes - Evaluation of degradation of coatings - Designation of quantity and size of defects, and of intensity of uniform changes in appearance
DIN 4726	Warm water surface heating systems and radiator connecting systems - Plastics piping systems and multilayer piping systems
EN ISO 7599	Anodizing of aluminum and its alloys - Method for specifying decorative and protective anodic oxidation coatings on aluminum
EN ISO 9223	Corrosion of metals and alloys - Corrosivity of atmospheres - Classification, determination and estimation
EN ISO 9227	Corrosion tests in artificial atmospheres - Salt spray tests
EN 10152	Electrolytically zinc coated cold rolled steel flat products for cold forming - Technical delivery conditions
EN 10169	Continuously organic coated (coil coated) steel flat products - Technical delivery conditions
EN 10217-7	Welded steel tubes for pressure purposes - Technical delivery conditions - Part 7: Stainless steel tubes
EN 10244-2	Steel wire and wire products – Non-ferrous metallic coatings on steel wire – Part 2: Zinc or zinc alloy coatings
EN 10346	Continuously hot-dip coated steel flat products for cold forming – Technical delivery conditions
EN 10088-2	Stainless steels – Part 2: Technical delivery conditions for sheet/plate and strip of corrosion resisting steels for general purposes
EN ISO 11654	Acoustics – Sound absorbers – Rating of sound absorption coefficients
EN 12020-2	Aluminum and aluminum alloys - Extruded precision profiles in alloys EN AW-6060 and EN AW-6063 - Part 2: Tolerances on dimensions and form
EN 12206-1	Paints and varnishes - Coating of aluminium and aluminium alloys for architectural purposes - Part 1: Coatings prepared from thermosetting coating powder
EN 12735-2	Copper and copper alloys – Seamless, round tubes for air conditioning and refrigeration - Part 2: Tubes for equipment
EN ISO 12944-ff	Paints and varnishes - Corrosion protection of steel structures by protective paint systems
EN 13501-1	Fire classification of construction products and building elements - Part 1: Classification using data from reaction to fire tests
EN 13501-2	Fire classification of construction products and building elements - Part 2: Classification using data from fire resistance tests

EN ISO 13760	Plastic pipes for the conveyance of fluids under pressure - Miner's rule – Calculation method for cumulative damage
EN 13964	Suspended ceilings - Requirements and test methods
EN 14037-1	Free hanging heating and cooling surfaces for water with a temperature below 120°C – Part 1: Pre-fabricated ceiling mounted radiant panels for space heating – Technical specifications and requirements
EN 14240	Ventilation for buildings - Chilled ceilings - Testing and rating
EN 15804	Sustainability of construction works - Environmental product declarations - Core rules for the product category of construction products
EN ISO 16120-2	Non-alloy steel wire rod for conversion to wire – Part 2: Specific requirements for general purpose wire rod
EN 16516	Construction products - Assessment of release of dangerous substances - Determination of emissions into indoor air
ISO 17455	Plastic piping systems - Multilayer pipes - Determination of the oxygen permeability of the barrier pipe
DIN 17611	Anodized products of wrought aluminium and wrought aluminium alloys - Technical conditions of delivery
DIN 18182-1	Accessories for use with gypsum boards - Part 1: Steel plate sections
EN 23270	Paints, varnishes and their raw materials; temperatures and humidities for conditioning and testing
DIN 24041	Perforated plates - Dimensions

4 TAIM – certification procedure

TAIM's central quality tool is the specially developed TAIM company certification, which is the prerequisite for membership in the Association of TAIM e.V.

The TAIM company certification encompasses a broad and in-depth range of quality criteria. Within the framework of the certification process, business processes are examined which form the basis for compliance with tolerances, including testing and evaluation procedures for material procurement and quality of the raw materials. It also focuses on aspects such as fire protection, sound insulation and mechanical strength as well as compliance with EN 13964 (suspended ceilings - requirements and test methods).

The certification has to be carried out by all members every year. This ensures that the products of the member companies have a consistently high level of quality. The TAIM certificate confirms successful company certification of the members.

5 TAIM -compliant metal ceiling systems

Metal ceiling systems that meet the technical and legal requirements of the TAIM TMMC include the following features / evidence:

1. Compliance with the technical requirements of the TMMC in its current version
2. Proof of conformity with standards in accordance with EN 13964 (CE marking / declaration of performance)
3. Proof of TAIM company certification
4. Management of an EPD (Environmental Product Declaration according to ISO 14025 and EN 15804) for the metal ceiling system

6 Terms and definitions

In addition to the definitions of EN 13964, the following terms apply to TMMC.

6.1 Metal ceiling system

Metal ceiling as a finished product, which consists of the system manufacturer's specifically defined and matched components.

For this purpose, the top fixing, suspension, the substructure, membrane and all to be considered connecting parts.

Metal ceiling systems can at the same time meet different requirements; they fulfill the properties guaranteed by the system manufacturer.

The minimum requirements of EN 13964 with the supplementary quality characteristics of the TAIM shall be met.

Non-metallic materials are included as far as approved by the system manufacturer.
 These may e.g. on the backside of the membrane loose or firmly connected, or be applied.

The membrane is always aligned with its visible side to the room side.
 In addition to the classic horizontal alignment - depending on the manufacturer - special designs such as inclined, concave, convex, polygonal, ... are also possible.

The metal membranes are usually individually removable and suitable for replacement.

Although different manufacturers may have the same system designations and similar technical or even identical specifications, it should be noted that system parts from different manufacturers – even if they carry a CE marking - are not interchangeable and are not always designed to fit together.

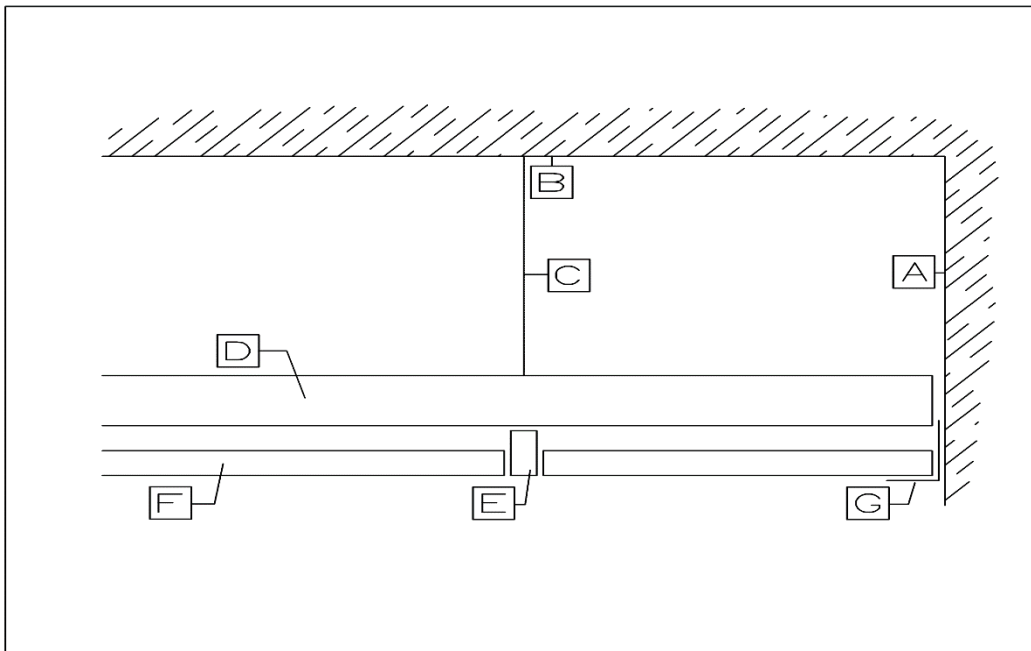

- A = Soffit / Wall
- B = Top fixing (e.g. anchor / screw – not part of the system)
- C = Suspension
- D = Secondary profile
- E = Primary profile
- F = Membrane
- G = Perimeter trim

Fig. 1 - General system design parts

6.1.1 Hook-on systems

Metal ceiling systems, whose membranes are mounted on a non-visible or only partially visible substructure.

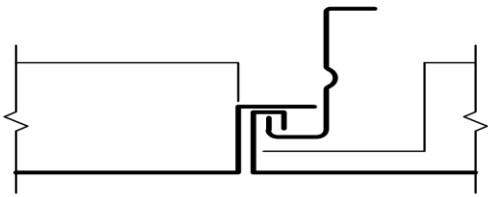

Fig. 2 – Example for a hook-on system

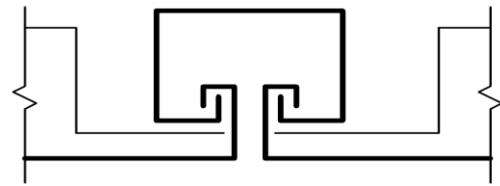

Fig. 3 – Example for a double hook-on system

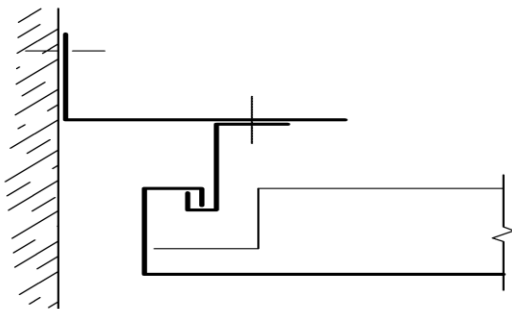

Fig. 4 – Example for a hook-on system at the perimeter

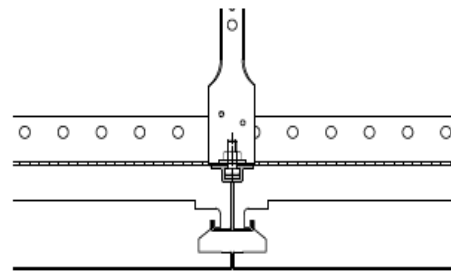

Fig. 5 – Example for a hook-on T profile system

6.1.2 Clip-in systems

Clip-in systems

Metal ceiling systems, whose membranes are clipped into a non-visible or only partly visible substructure.

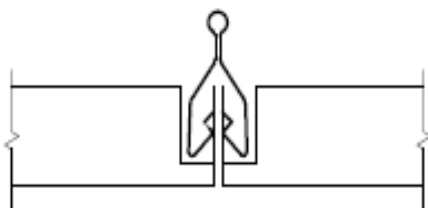

Fig. 6 – Example for a clip-in system with a non-visible profile

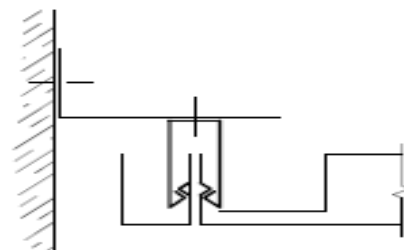

Fig. 7 – Example for a clip-in system with perimeter trim

Clip-in swing-down system

Metal ceiling systems, whose membrane elements are clipped on to a concealed or only partly covered substructure and which can individually be swung-down. Cut or special size membranes can generally not swing-down.

The membranes are held in the swing-down position by special retaining lugs to the substructure. The membranes can be moved in the folded state.

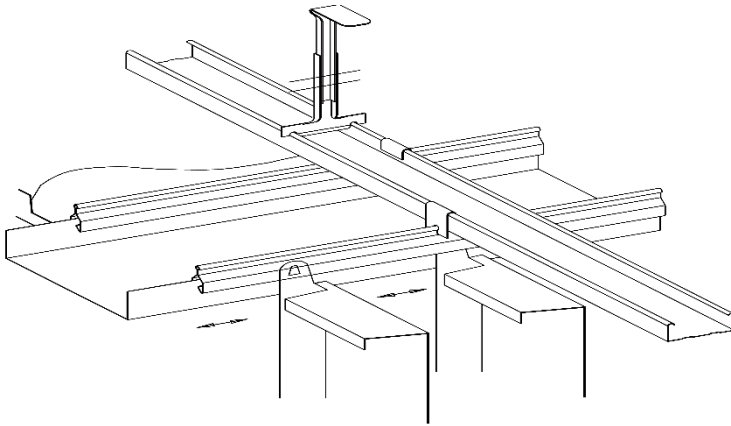

Fig. 8 – Example for a clip-in and swing-down system

6.1.3 Post-cap systems

Linear installation – Post-cap visible

Metal ceiling systems whose visible post-cap profiles form a linear geometry.

The membranes can be produced as lay-on, lay-in, hook-on, clip-in or removable system.

If equipped with special hinging and locking elements, the membranes can be swiveled or folded down over their sides or longitudinal axes. Also movable swing-down membranes are possible.

The post-cap profiles have a width of 50 to 300 mm and are - depending on the specifications of the system manufacturer - suitable for fixing partitions.

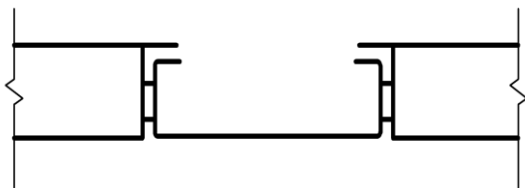

Fig. 9 – Example for a C-post-cap system



Fig. 10 – Example for a lay-on post-cap system

Cross post cap system with – Post cap visible

The visible post cap profiles are usually arranged in a square or rectangular design.

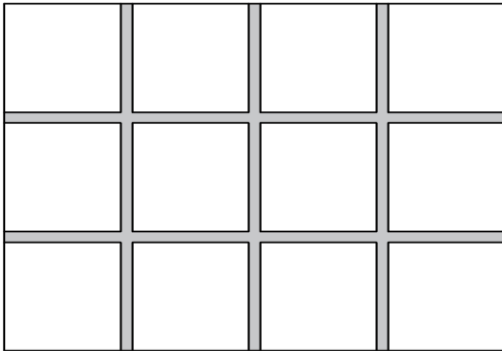

Fig. 11 – Example for a Cross post cap system
Top view

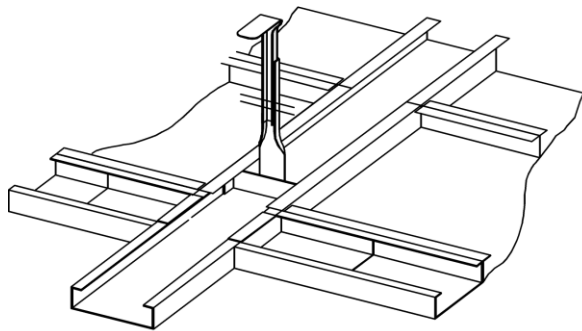

Fig. 12- Example for a cross post cap system
suspension.

Cross post cap system – Post cap visible – with crossing boxes

The visible post-cap profiles are designed for a mostly square or rectangle-oriented geometry. At the intersections, crossing boxes are installed as a separate component or as an optical node.

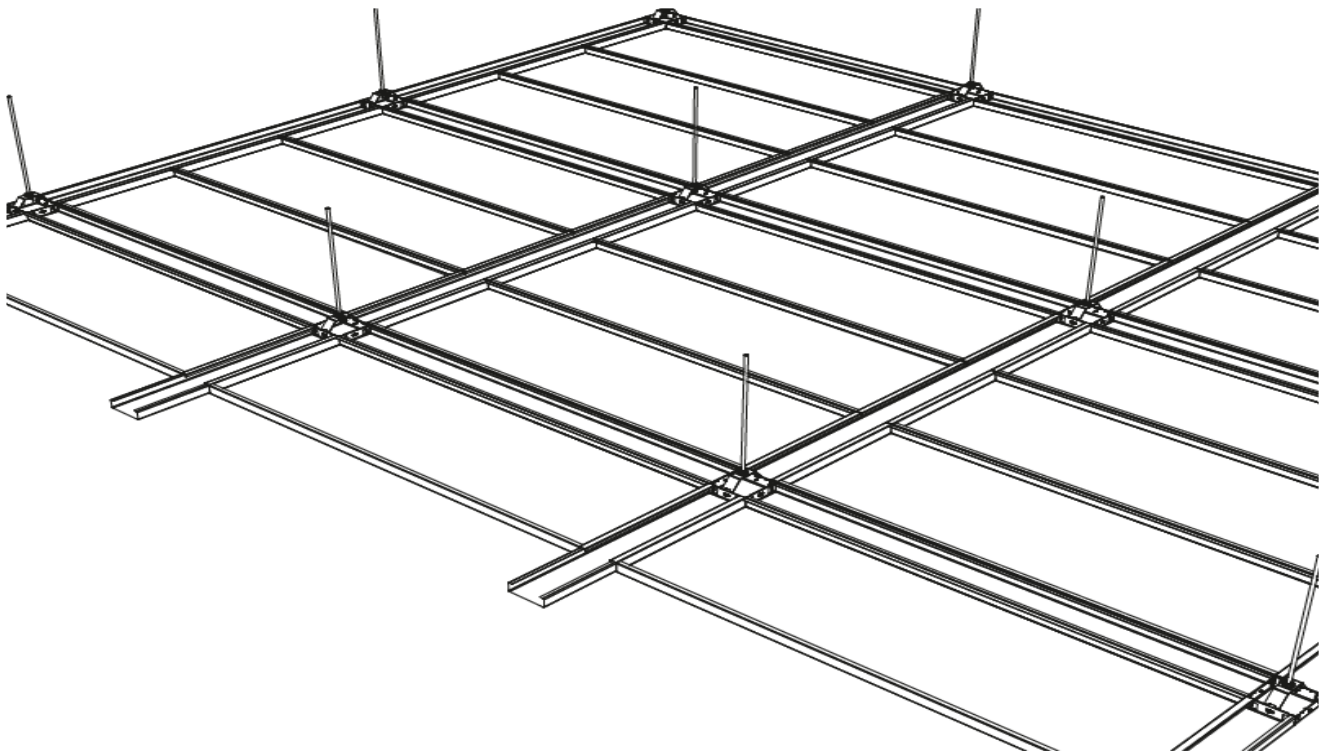

Fig. 13 – Example for a cross post cap system with crossing boxes

6.1.4 Tile ceiling system

Metal ceiling systems mit square membrane elements.

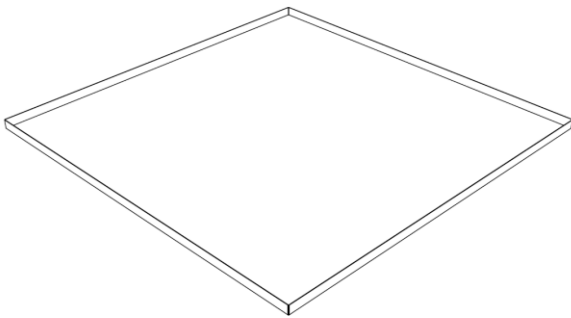

Fig. 14 – Example for a lay-in tile with L-turn-up

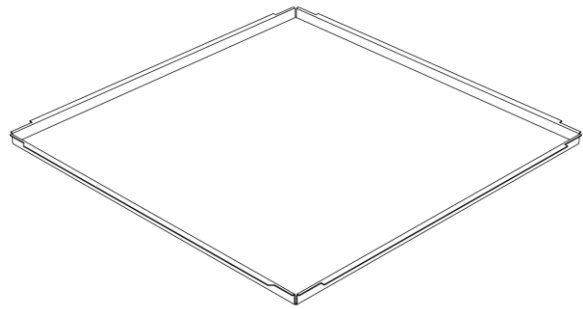

Fig. 15 – Example for a lay-in tile with Z-turn-up

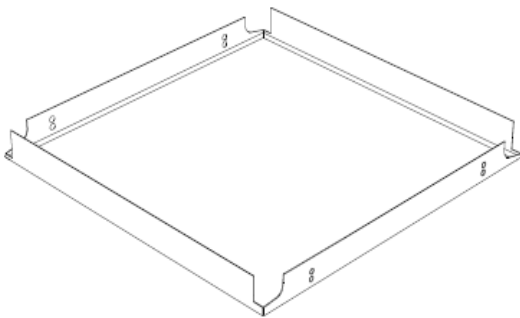

Fig. 16 – Example for a clip-in tile with L-upstands on 4 sides

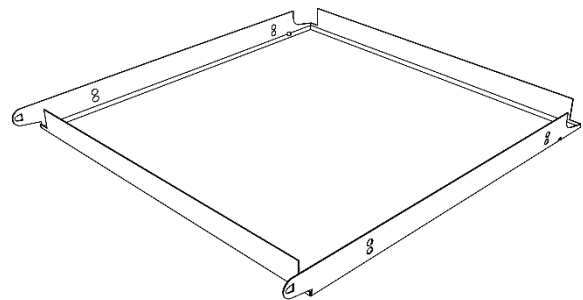

Fig. 17 – Example for a clip-in swing-down tile with L-upstands on 4 sides

6.1.5 Lay-in- / Lay-on systems

Metal ceiling systems, whose membranes are laid in or on a visible substructure.

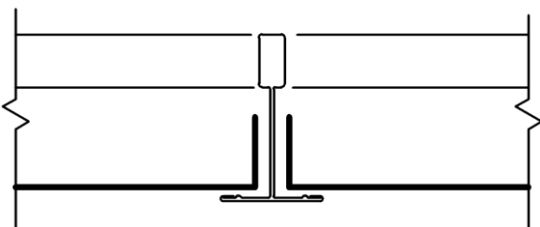

Fig. 18 – Example for a lay-on system T-profile construction with lay-on membrane

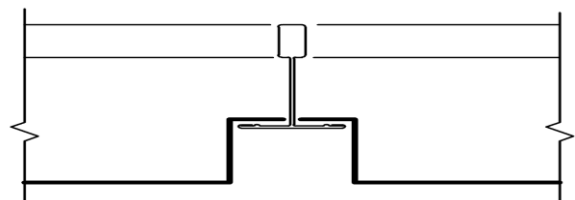

Fig. 19 – Example for a lay-in system T-Profile construction with lay-in membrane

6.1.6 Swing-down systems

Metal ceiling systems, whose membranes can be swung down over the longitudinal or short sides. The membranes have either specially shaped retaining lugs or swing & latch components attached to them. During swinging down, the membranes are connected to the substructure. The hinging and locking elements can be visible or hidden.

Depending on the design, the membranes can be moved in the folded-down state.

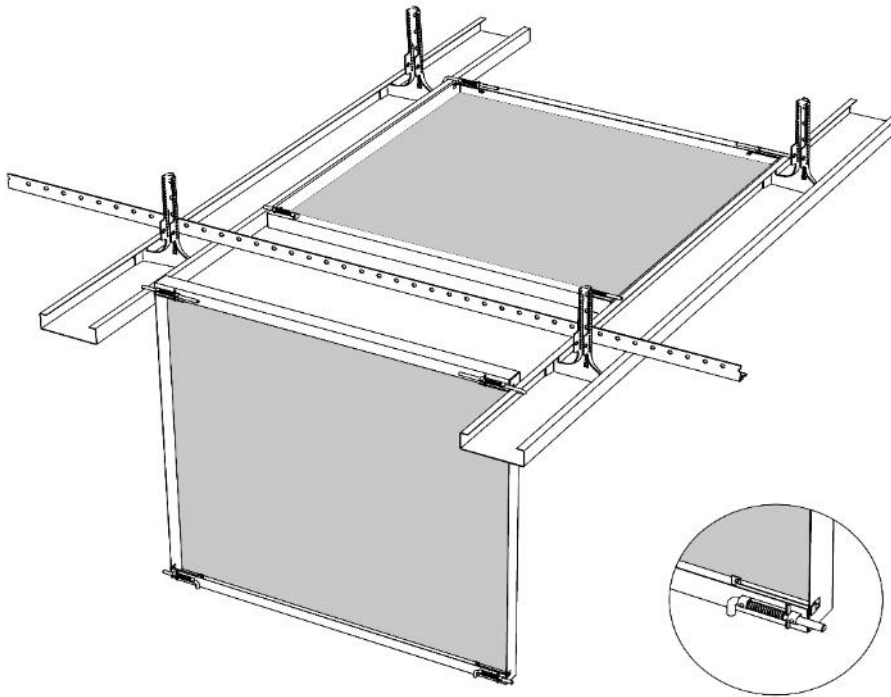

Fig. 20 - Example for a post cap ceiling with swing-down and movable membrane

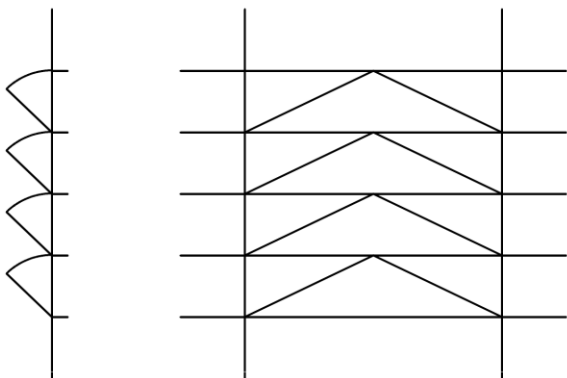

Fig. 21 - swing direction over long side of the membrane - in the same direction

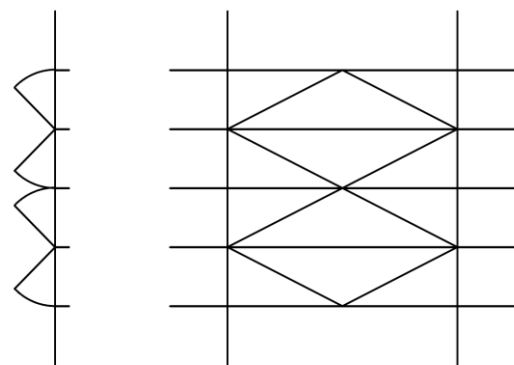

Fig. 22 - swing direction over long side of the membrane - in opposite directions

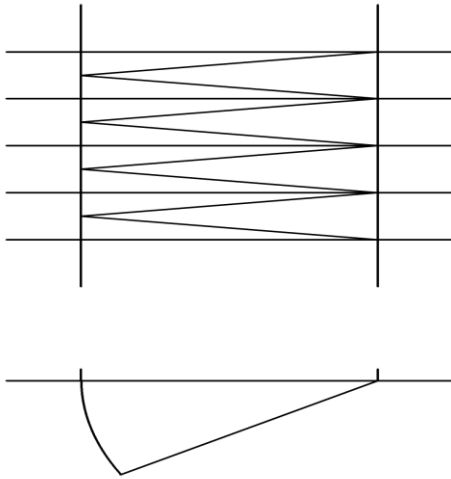

Fig. 23 - swing direction over short sides in the same direction

6.1.7 Inspection hatches

Components of the substructure and/or membrane, which are equipped with an access facility so that certain parts of the membrane can be removed or opened and access to the substructure and/or the ceiling cavity is possible.

Metal ceilings are usually designed so that the membrane can be removed individually and are suitable for reuse.

There are many variants available, depending on the manufacturer and the system:

- a) tool-free dis- & re-assembly of the membrane (by removing ..)
- b) dis- & re-assembly only with tools
- c) membrane equipped with additional bearing and locking parts for swing-down, moving ...
- d) membranes with shut-off devices
- e) membranes with additional measures such as safety ropes
- f) inspection flaps fit to the respective system

Inspection hatches are also subject to the minimum requirements of EN 13964 (safety in the event of fire - acoustics - mechanical strength - heating/cooling technology...).

6.1.8 Ceiling islands

Individual randomly arranged metal ceilings in the room without any connection to the adjacent walls are usually called ceiling islands.

Ceiling islands are a special form of suspended ceilings, but from the point of view of TAIM they are always to be regarded as ceilings within the scope of EN 13964.

Ceiling panels can be fixed directly to the soffit (even without a substructure) or suspended from the soffit. The peripheral edges can be formed in different shapes or bordered with additional frame profiles.

If individual ceiling panels are mounted side by side, a clear distinction between "ceiling island" and "suspended ceiling" and a "closed / or open ceiling" is not possible.

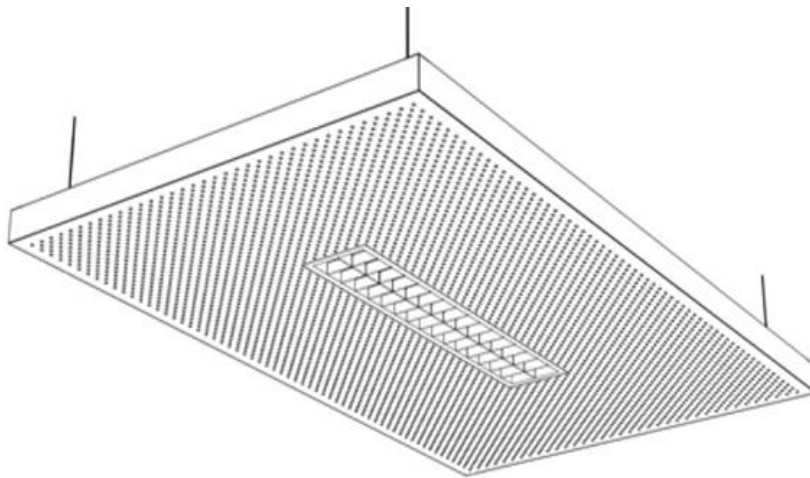

Fig. 24 - Example for a ceiling island

6.1.9 Double-walled baffle systems

Are metal ceiling systems with vertically arranged double-walled membranes. Both vertical sides and the lower side view to the room side are formed as visible sides. Depending on the type of installation, the end of the baffles can be designed either open or closed.

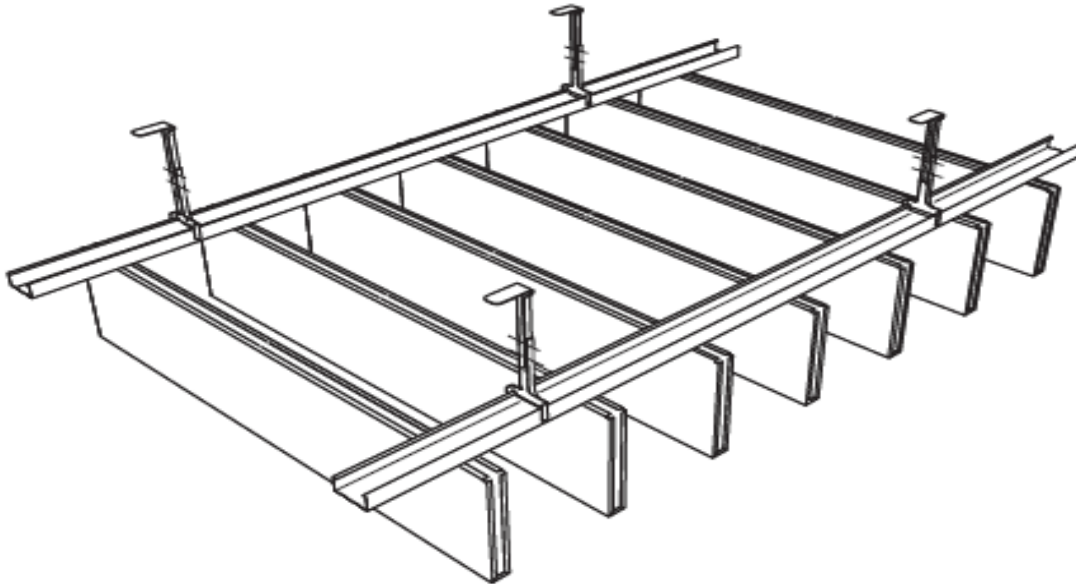

Fig. 25 - Example for a baffle ceiling



Fig. 26 – Example for a double-walled baffle made from bent or roll formed metal.



Fig. 27 – Example for a double-walled baffle made from extruded aluminium

6.1.10 Single-walled baffle systems

Are Metal ceiling systems with vertically arranged single-walled membranes. Both sides are designed to be visible. Unless otherwise indicated, the edges of the material are not coated.

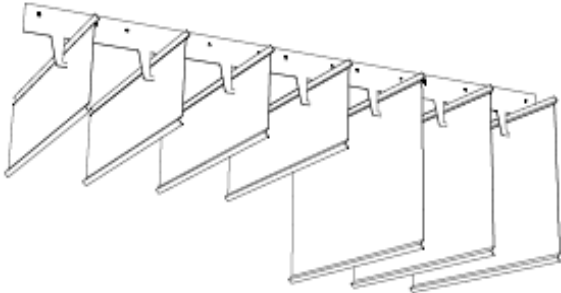

Fig. 28 - Example for a single-walled baffle ceiling with main runner



Fig. 29 - Example for a single-walled baffle

6.1.11 Linear panel systems

Are metal ceiling systems with linearly arranged membranes mostly with the ends open. Linear panel ceilings have membranes with a width up to max. 400 mm, which are turned up on the two longitudinal sides and whose length corresponds to a multiple of the width. By means of longitudinal connectors, panels can also be laid as "endless panels". The membranes are connected by clamps, clips or as suspension systems with the substructure.

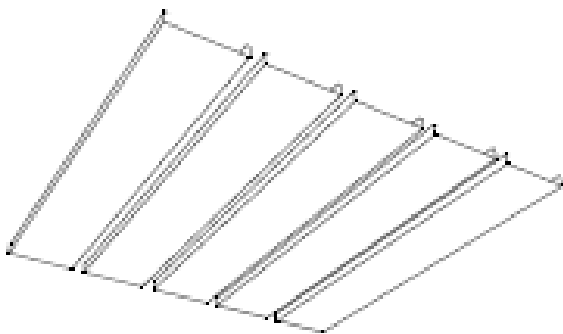

Fig. 30 - Example for a linear panel system with open joint

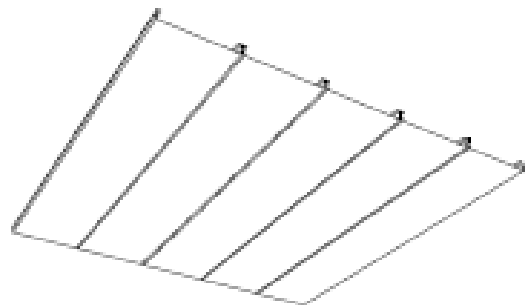

Fig. 31 – Example for a linear panel system with closed joint

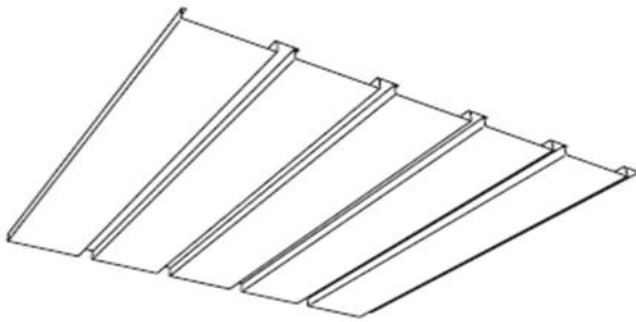

Fig. 32 – Example for a linear panel system with a closed joint

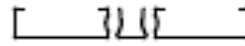
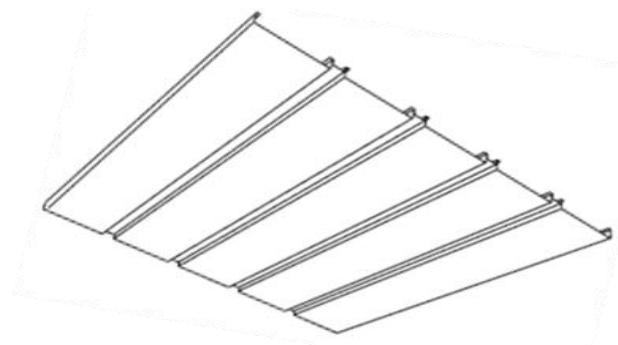

Fig. 33 - Example for a linear panel system with infill strip

6.1.12 Open cell systems

Open cell ceiling systems consisting of single-walled or double-walled membranes arranged in a cross-connection. The vertically arranged membranes are connected at an angle of 90 degrees as an element to each other. Both vertical surfaces are designed as visible sides.

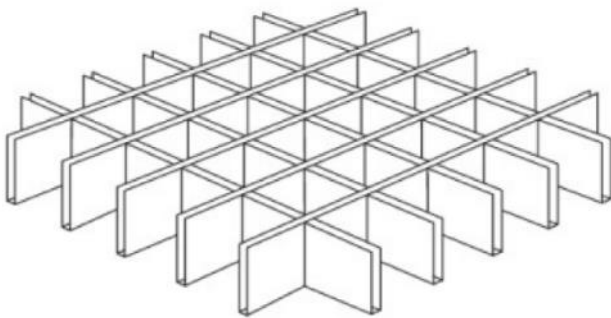

Fig. 34 - Example for a double-walled open cell system
the lower visible edge is usually coated

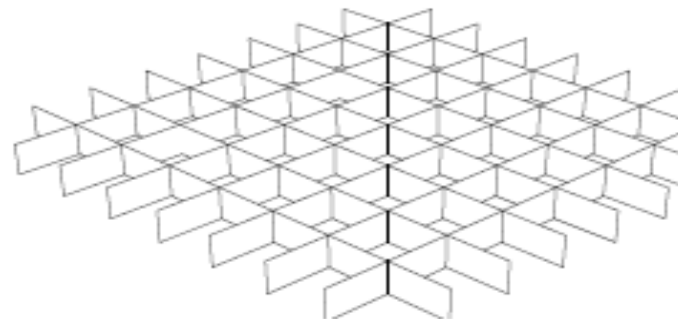

Fig. 35 - Example for a single-walled open cell system
the lower visible edge is usually not coated

6.1.13 Expanded metal ceiling systems

Are metal ceiling systems with a membrane of expanded metal mesh.

Expanded metal consists of sheets of semi-finished products, with openings in the surface, which are produced by stretching metal sheets with staggered cuts causing deformation without any loss of material. The edges may be factory-machined, e.g. with stiffening frame profiles.

In the case of expanded metal ceiling panels, the panel length is usually 90 ° offset from the mesh length.

Depending on the system, concealed or visible welds are used for expanded mesh membranes.

Sharp edges can occur when the material is cut.

To avoid injury, wear suitable protective equipment.

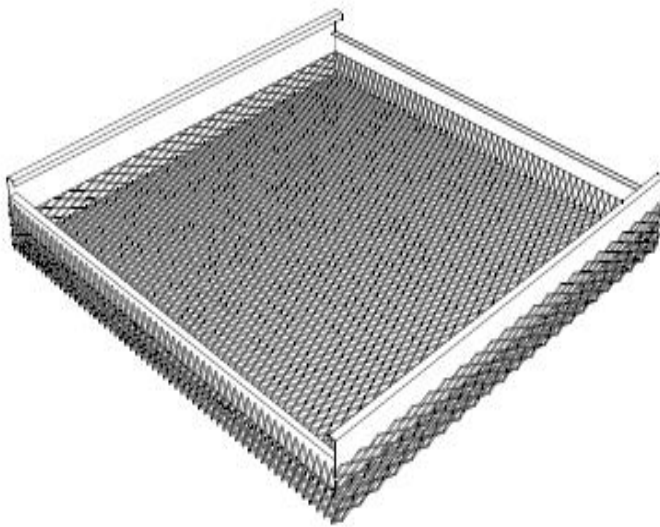

Fig. 36 - Example for an expanded metal tile with internal frame

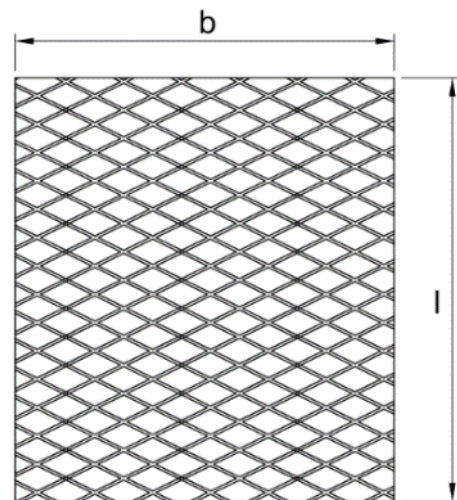

Fig. 37 – Example for an expanded metal sheet sheet length and width

6.1.14 Composite elements

Metal membranes with at least one additional layer (thickness ≥ 3 mm / weight ≥ 150 g/m²), in which the different layers are connected.

Inlays or pads may also be non-metallic materials.

Metal membranes with tissue (inserted or glued in) are not to be considered as composite elements.

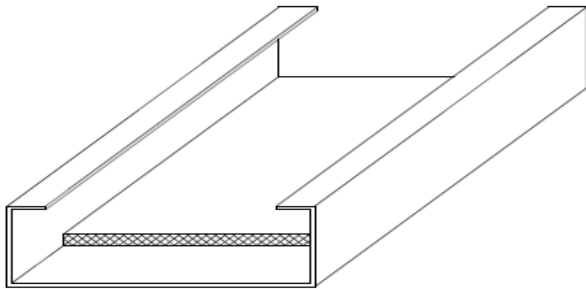

Fig. 38 – Example for a metal composite element with inlay

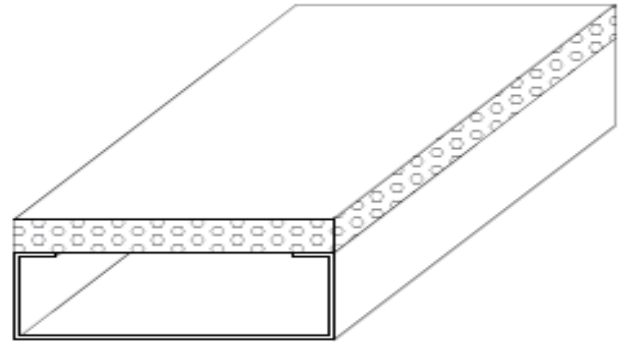

Fig. 39 - Example for a metal composite element with lay-on

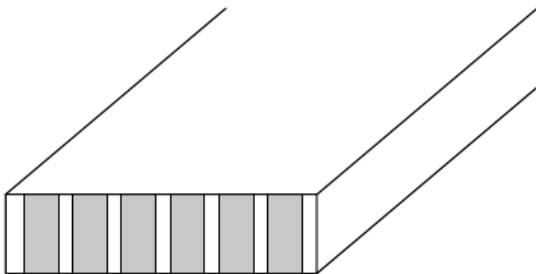

Fig. 40 - Example for a metal composite element consisting of aluminium honeycomb centre with sheet metal covering on both sides

6.2 Heating and cooling ceiling systems

6.2.1 Heating-/cooling medium

Water-run heating and cooling ceiling systems made of metal are ceiling systems with water-carrying tubes installed on the back of the metal membrane, including the required connection and distribution tubes within a room up to the control valves. The flow temperature is to be coupled to a dew point control system.

Depending on the required heating / cooling capacity, the heating / cooling ceiling usually consists of active and passive membranes, both belonging to the heating / cooling ceiling forming a system.

Additional air ducts can be used, to supply the room with or without pre- treated air, or used to remove exhaust air.

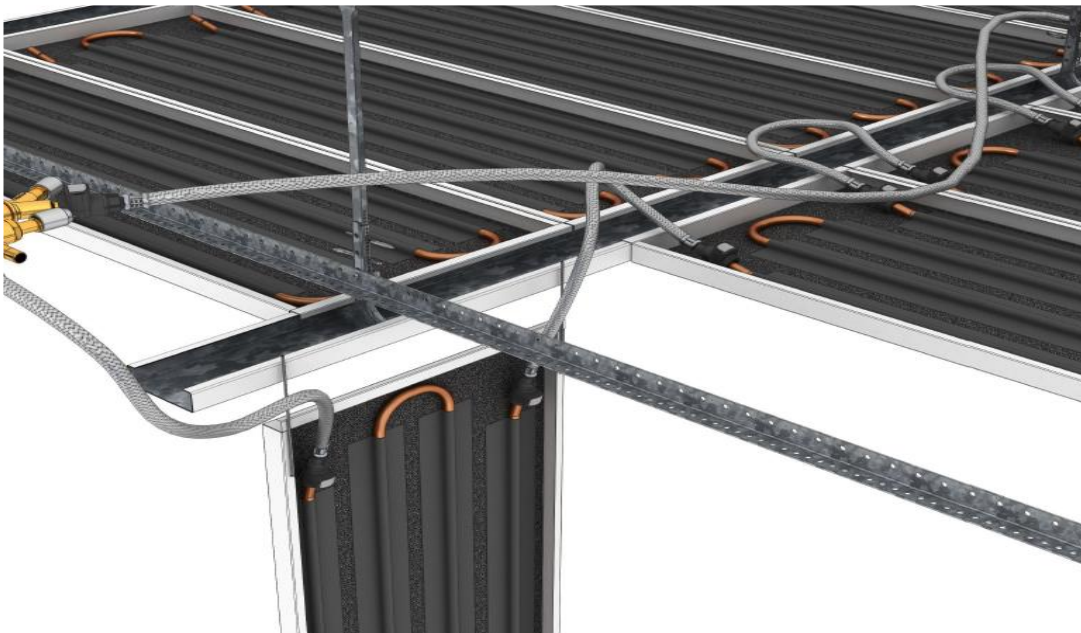

Fig. 41 - Example for a post-cap ceiling with heating and cooling elements

PCM (Phase Changing Materials)

Cooling ceilings of this type are equipped with storable PCM. The passively absorbed heat during the day is dissipated during the following night with significantly lower energy consumption.

Thermal active component systems (TABS)

Are metal ceiling systems that use the storage capacity of the buildings concrete soffit. The heat exchange between the soffit and the room is carried out by the type of attachment of the substructure and membranes and the nature and type of installation.

Membranes can additionally be equipped as active cooling ceiling elements.

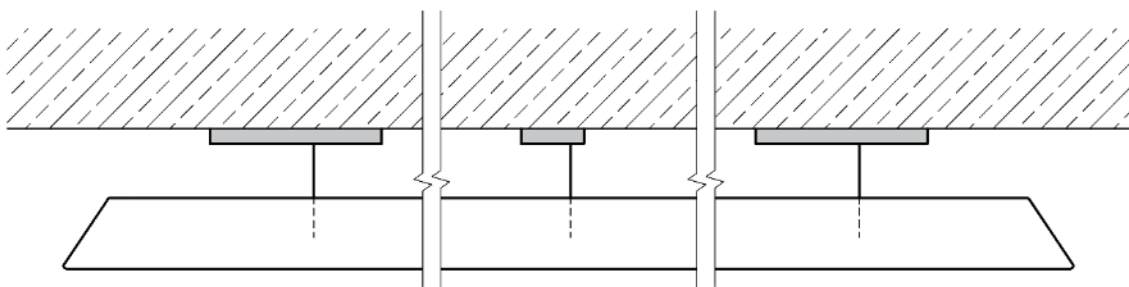

Fig. 42 – Example for a thermal active ceiling island (tabs)

6.2.2 Active and passive elements

Heating and cooling ceiling systems consist of active and passive areas, which as a whole form a suspended surface for the heating and cooling ceiling systems.

Active elements:

Metal ceiling membranes with integrated heating / cooling system on the back.

Passive elements:

Metal ceiling membranes that together with active elements form a ceiling surface.

The passive element fulfills the same properties as the active element with regard to fire behavior and sound insulation.

Retrofit options for active and passive membranes shall be agreed with the system manufacturer.

6.2.3 Tubing

A tubing consists of heat-conducting profiles and meandering tube, which are interconnected. It consists of at least two rows of tubes in connection with the heat-conducting profiles. Axial spacing and geometry differ manufacturer-specific.

Unless otherwise stated, it is up to the system manufacturer to determine the direction, number, modules and dimensions, as well as the type of fixing in the membranes.

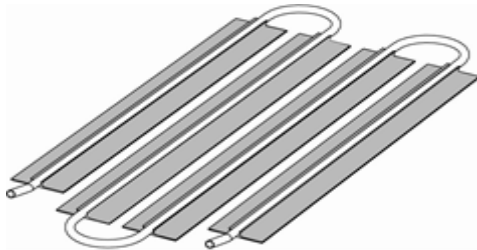

Fig. 43 - Example for a tubing for heating and cooling ceiling consisting of heat conduction profiles and pressed-in tubes

The tubing is introduced in different ways to the back of the membrane, depending on the requirements and the system manufacturers.

The most commonly used techniques are:

- a) loosely inserted frets, optionally with securing elements
- b) Frets adhered to back of membrane
- c) frets with integrated magnetic strips

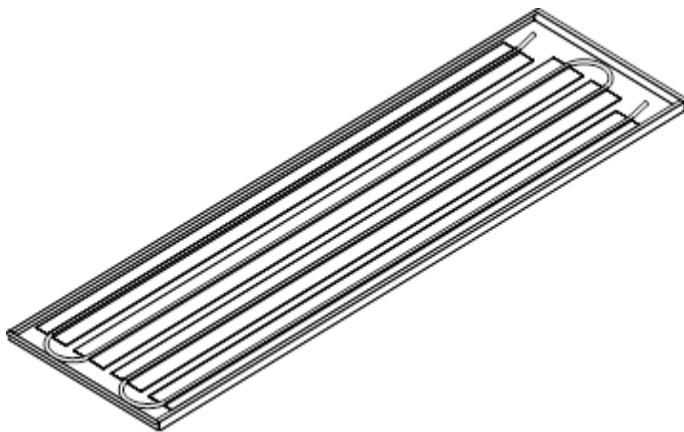

Fig. 44 - Example for an active metal ceiling membrane for heating and cooling with applied tubing.

6.2.4 Heat conducting profile

Heat-conducting profiles are usually made of aluminum or steel profiles, which are placed on the back of the metal ceiling membrane intended to fix the water-carrying tubes. The heat-conducting profiles help to transfer the heat/cold from the water medium to the metal surface of the membrane. The heat-conducting profiles may vary in size, dependent on the manufacturer.

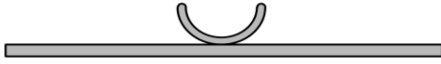

Fig. 45 - Example for a conducting profile with tube fixing



Fig. 46 - Example for a conducting profile with tube fixing and magnetic strip

6.2.5 Meander

Meanders consist of at least two rows of tubes usually S- or serpentine shaped, made from copper or stainless steel tubes, oxygen diffusion-tight plastic pipes or multi-layer composite pipes; outer diameter of the tubes from approx. 6 mm to approx. 15 mm. The meanders are usually pressed into the conducting profiles to improve heat transfer.

a) Copper tubes

Usually copper tubes acc. to EN 12735-2 standard are used for this purpose.

b) Stainless steel tubes

Welded tubes made of stainless steel acc. to EN 10217-7 standard.

c) Plastic- und multi-layer composite tubes

Pipe meanders using plastic or multi-layer composite tubes, which are oxygen-impermeable, can be used as an alternative acc. to DIN 4726 / EN ISO 13760 / ISO 17455 standards.

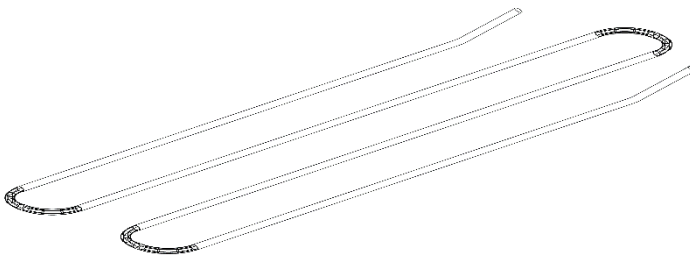

Fig. 47 - Example for a meander with 4 bars / both end bars are bent upwards.

6.2.6 Meander in thermally conductive inserts

Meanders may be incorporated in highly heat-conductive materials, such as e.g. graphite, pressed or embedded in. These elements are used on the back side in metal membranes.

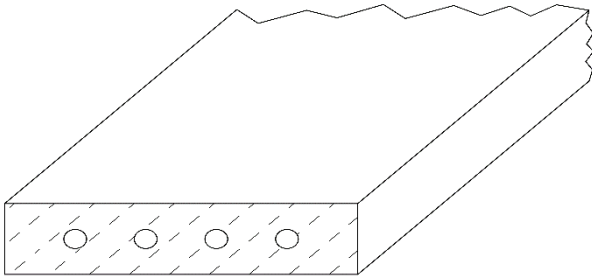

Fig. 48 - Example for a pre-fabricated membrane with embedded meander

6.2.7 Capillary tube mats

Plastic tube mats with an outside diameter of about 4 mm to about 8 mm. The individual plastic capillary tubes are usually connected to the front sides by means of a straight supply and return tube.

Capillary tube mats on the back of the membrane are

- a) Laid in or
- b) Glued in or
- c) Additionally secured by special brackets.

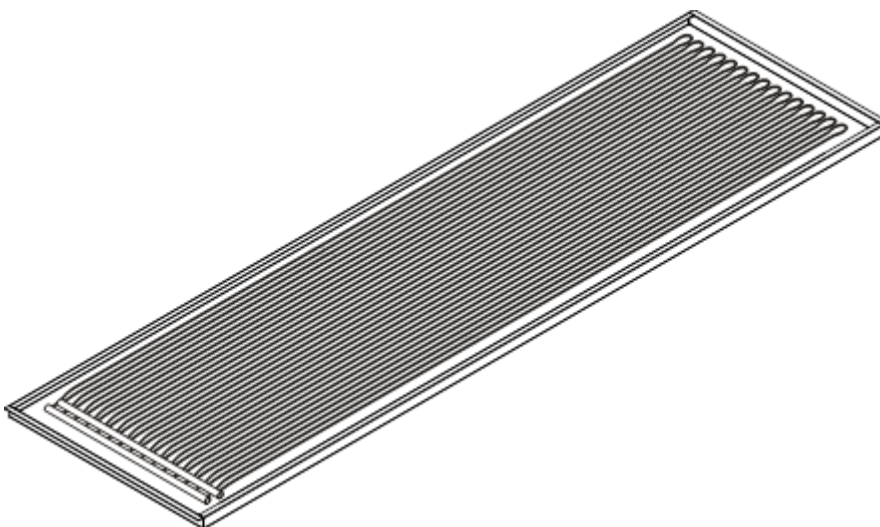

Fig. 49 - Metal ceiling membrane with laid in capillary tube mats

6.2.8 Connection and distribution conductions

Connecting and distributing conductions can be made of plastic tubes, stainless steel covered hoses, stainless steel hoses or also from multi-layer composite tubes.

- a) Supply pipes
are used to connect the active heating / cooling ceiling elements to the distributor.
- b) Connection pipes
provide the hydraulic connection of two active elements.
- c) Distributors / manifold bars / Supply pipes
water the individual fields with heating or cooling medium.
- d) Distributors / manifold bars / Return pipes
- e) Regulating valve
- f) Shut-off valve

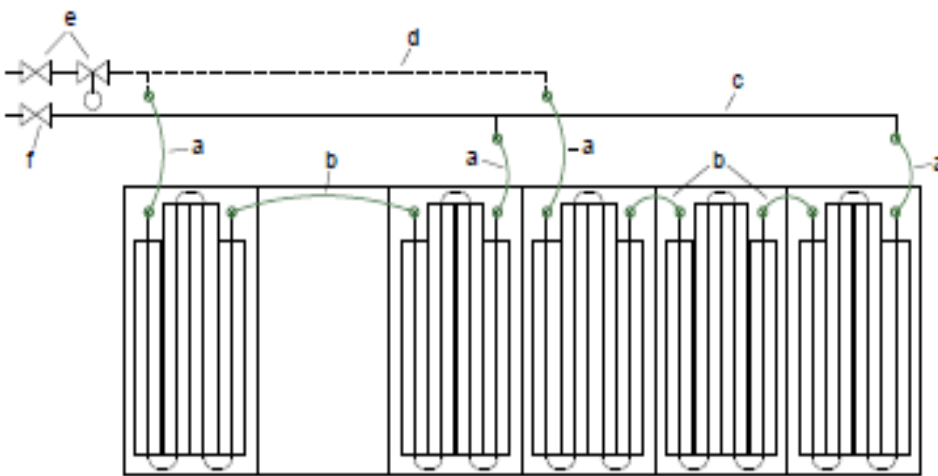

Fig. 50 - Example for a connection of active heating ceiling tiles

6.2.9 Plug in connectors

Plug in connectors - usually detachable - are used to connect to supply lines and / or connect to with other meanders and / or the return pipes.

6.2.10 Heating- or cooling fields

A heating or cooling field consists of one or more active elements, which are connected together in series. Passive elements may also be included in between active elements.

6.2.11 Control area

A control area consists of one or more heating or cooling fields, which are connected in parallel. The control areas are usually selected by room or axis. The size of the control areas is limited by the regulation unit.

6.3 Metal ceiling membrane

Thin gauge metal component up to a nominal thickness of 3 mm, which forms the visible surface of the suspended ceiling, provided that this is not a visible part of the substructure.

Metal ceiling panels are membranes with usually 4-sided turned up edges.

If not explicitly determined by the system manufacturer, the membrane is not designed to support other loads.

6.3.1 Functional upstands

A functional upstand is the edge of the membrane which establishes the non-positive or positive connection to the substructure.

6.3.2 Stabilization upstands

Upstands that do not serve as a non-positive or positive connection to the substructure.

The upstands can also be designed differently for the same panel dimensions in terms of geometry and dimensions.

6.3.3 Membrane upstands

The edge shape is determined by the system manufacturer.

The edge surfaces are only designed as a visible side if separately agreed.

Table 1 – Examples for metal ceiling membranes / tiles edge details







No.	Description	Sketch
1	L-upstand	
2	L-upstand with bevel	
3	C-upstand	
4	Hook on upstand „Type A“	
5	Hook on upstand „Type B“	
6	Z-upstand	
7	L-upstand with hinge or latch	

Table 2 – Examples for expanded metal ceiling edge details













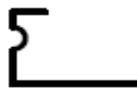

No.	Description	Sketch
1	Expanded metal with edge protection	
2	Expanded metal with pressed edge	
3	Expanded metal with interior frame	
4	Expanded metal with external frame	
5	Expanded metal with top mounted frame	
6	Expanded metal with side mounted frame	

Table 3 - Examples for linear panel edge details

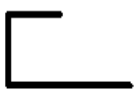
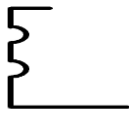
No.	Description	Sketch
1	C-upstand with bead	
2	F-upstand with bead	
3	C-upstand	
4	C-upstand with double bead	
5	R-upstand	

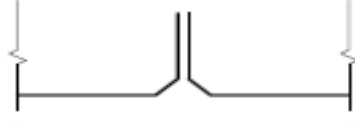
6.3.4 Joint types

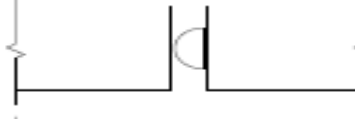
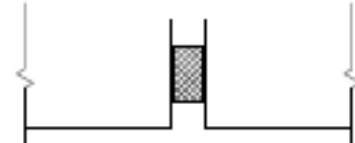
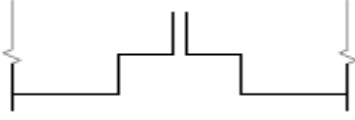
Table 4 – Examples for typical joints

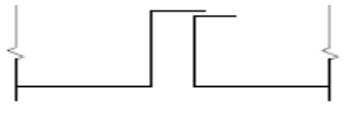
No.	Description	Sketch
1	without bevel	
2	with bevel	
3	with gap	
4	with distancing pieces	
5	with gasket	
6	with step	
7	with infill strip	
8	with closed joint	

6.3.5 Ropes as operating and assembly aid

- a) Ropes, which limit the pivoting range of the panel when folding down the ceiling panels
- b) Ropes, which are used in removable ceiling panels for suspending the ceiling panels.

They are not safety parts and - unless otherwise stated - are not designed for dynamic loads. Depending on the panel dimensions, reinforcements in the ceiling panels and/or in the area of the substructure are recommended.

If not specified by the system manufacturer, ropes and possible strengthening measures are to be agreed upon.

6.4 Substructure

An essential part of the finished product consisting of system-specifically defined metal components as intended for a system defined by the system manufacturer.

The substructure is to be designed for installing the membrane element and has to bear the entire dead load of the system together with the expected dead load of the membrane.

The information provided by the system manufacturer shall be observed.

The number of fixing points shall be such that the permissible load capacity of the anchors is not exceeded.

For this purpose, suspension, substructure profiles and all connecting parts are to be considered.







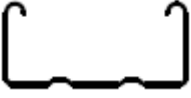

Unless specifically stated by the system manufacturer, the substructure is not designed to carry extra loads, e.g. partitions, installed items or parts, cables, lights etc.

The minimum requirements of EN 13964 shall be met.







6.4.1 Profiles

The geometries are manufacturers own design with different characteristics.

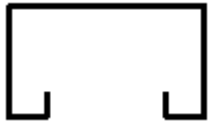
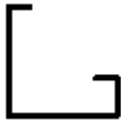
Table 5 – Examples for different ceiling profiles:

	Section	Description	Abbreviation
A		C-Ceiling profile	CD-Profile (DIN 18182-1)
B		U-Ceiling profile U- reinforcing section U-Wall floor/ceiling profile U-Profile	UD-Profile (DIN 18182-1) UA-Profile (DIN 18182-1) UW-Profile (DIN 18182-1) U-Profile
C		C-Dry wall stud	CW-Profile (DIN 18182-1)
D		Lay-on post cap	AB-Profile
E		C-Post cap	CB-Profile
F		G-Post cap	GB-Profile
G		C-Post cap with groove	CN-Profile
H		Hook on profile	E-Profile

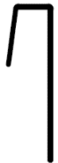
Continuation of Table 5 - Examples for different ceiling profiles

	Section	Description	Abbreviation
I		Double hook-on profile	DE-Profile
J		G-Profile	G-Profile
K		Clip-in profile	K-Profile
L		T-profile	T-Profile
M		T-Hook-on profile	TE-Profile
N		V-Profile	V-Profile
O		U-Carrier profile	U-Carrier profile
P		Linear panel-carrier-profile	Carrier profile

6.4.2 Suspension

Are parts of the substructure which are connected to the load-bearing components from the soffit. Since the soffits always vary so do the top fixings, anchors and the like are not considered as part of the suspension. If the fixing used is not approved by the system manufacturer, it is the installers responsibility to test and certify it.

Table 6 - Examples for non-pressure-resistant suspension options



	
<p>Fig. 51 – quick adjustment hanger</p>	<p>Fig. 52 – Nonius upper- / lower section with one safety splint</p>

Table 7 – Examples for pressure-resistant options

	
<p>Fig. 53 – Nonius upper- / lower section with two safety pins</p>	<p>Fig. 54 - Nonius upper- / lower section with unequal U-safety pin</p>
	
<p>Fig. 55 – Threaded rod</p>	<p>Fig. 56 - Nonius upper- / lower section with two safety splints</p>

6.4.3 Top fixing

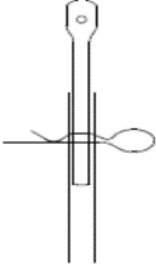
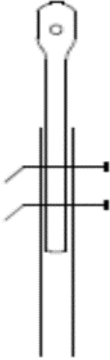
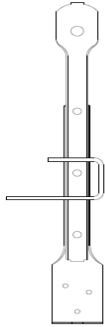
Fixing such as anchor and/or screws, which connects the hanger or substructure with the load-bearing component (soffit).

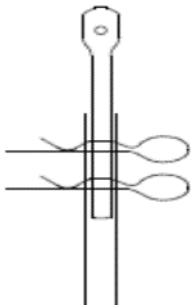
6.4.4 Suspension height

Suspension height is the total height of the metal ceiling system viewed from the lower edge of the soffit to the lower edge of the membrane surface visible from the room.

6.4.5 Connector

Fastening part intended to connect the hanger and substructure parts.

6.4.6 Primary grid

Substructure which is connected to the soffit and is designed either for the fixing of the secondary grid or to carry the membranes.





6.4.7 Secondary grid/carrier profiles

Substructure which is connected to the primary grid and designed to carry the membranes.

6.5 Perimeter trims

Manufacturer-specific geometries are shaped with different characteristics.

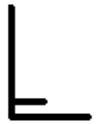
Table 8 – Examples for typical perimeter trims

	Section	Description	Abbreviation
A		L-Trim – unequal lengths	Lu-Profil
B		L-Trim – equal lengths	Lg-Profil
C		W-Trim with shadow gap	Ls-Profil
D		F-Trim	Fr-Profil
E		W-Trim with shadow gap	Fs-Profil
F		U-Perimeter trim	Ur-Profil

6.5.1 Load bearing perimeter trim

Perimeter trim between membrane/substructure and enclosure walls.

Load-bearing perimeter trims are designed to bear the load of the substructure and/or the membranes.

6.5.2 Non load-bearing perimeter trim

Perimeter trims between membrane/substructure and enclosure walls.

Non-load-bearing perimeter trims are not designed to bear the load of the substructure or membranes.

6.6 Perforations

Penetrations of the membrane with different shapes, dimensions and distance to each other.
 Micro perforations are perforations with a diameter ≤ 1 mm.

6.7 Axial dimension

The axial dimension of the membrane is the nominal size including 2x the nominal half joint dimension.
 The axial dimension of modular grid ceilings is the distance from post cap center to center.

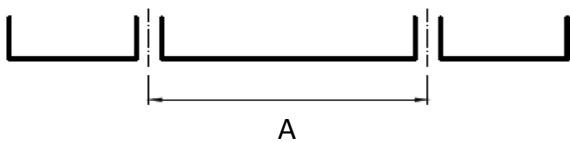

Fig. 57 - Axial dimension of a membrane

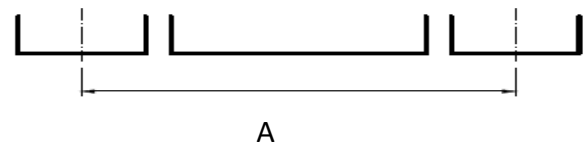

Fig. 58 - Axial dimension of a post-cap ceiling

6.8 Module dimension of membrane

Is the nominal size of the membrane plus the nominal joint width.

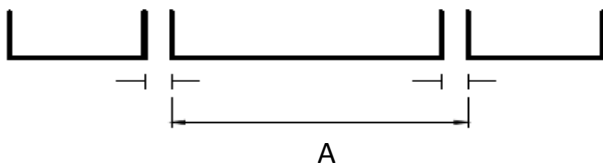

Fig. 59 - Module dimension of a membrane

6.9 Durability range - Corrosion protection

In addition to the corrosivity category or exposure class, the required durability range is crucial for the correct selection of suitable corrosion protection measures.

The term “durability range” defines the functional - not the aesthetic - service life of the existing protective system before the first major maintenance.

The durability range is not a “guarantee time”.

Durability is a technical consideration that can help the owner set up a maintenance program.

Some standards divide the durability into different classes. However, the respective durability ranges or classes are not identical in all standards, which can lead to misunderstandings.

For economic reasons, TAIM recommends a standard minimum durability range of 15 to 25 years, which is stated in most standards - including ISO 12944, which is explicitly not applicable to metal ceilings, as it only takes material thicknesses from minimum 3 mm into account – as durability range high (H).

6.10 Responsible / Participants

6.10.1 Building designer

The building designer is responsible for the selection of the correct metal ceiling systems with the technical specifications and its comprehensively described performance when planning his projects.

The project-specific requirements, taking into account the applicable standards and technical regulations, shall be in accordance with the choice of the appropriate system.

6.10.2 Installation company

The installation company has to fulfill the requirements of the building designer and the system manufacturer. Deviations shall be agreed with the building planner or the system manufacturer.

An installation company, which independently combines individual components or components of different systems to form a ceiling system, becomes (in terms of liability) the system manufacturer.

6.10.3 System manufacturer

The system manufacturer is the one who combines all the individual components to a ceiling system. He has to ensure the agreed characteristics.

The system manufacturer within the meaning of the TMMC is to be equated with the manufacturer within the meaning of the Construction Products Regulation.

7 Requirements on metal ceiling systems

The membranes and essential parts of the substructure shall be made of metal.

The entire substructure, including the connecting parts and membranes of a metal ceiling system, shall all be coordinated with each other.

The Construction Products Regulation (CPR) determines basic requirements for buildings.

Directly derived from this are the applicable harmonized European, national standards and technical regulations, which also apply to construction products.

Basic requirements for construction works according to the Construction Products Regulation (EU) No. 305/2011):

1. Mechanical resistance and stability
2. Safety in case of fire
3. Hygiene, health and the environment
4. Safety and accessibility in use
5. Protection against noise
6. Energy economy and heat retention
7. Sustainable use of natural resources

For metal ceiling systems the EN 13964 standard shall also be considered.

Unless otherwise stated, metal ceiling systems are designed to bear their own dead loads, but can also bear extra loads if specially approved.

Only parts approved by the system manufacturer shall be used.

All information applies to horizontally installed metal ceiling systems.

Inclined ceiling areas and/or bulkheads are to be considered in individual cases.

The system shall be tested for structural load and function (e.g. swing-down operation).

The materials are designed for use in normal climate conditions for spaces without corrosive pollution and without condensation (equivalent to Class A according to EN13964 Table 8).

Further requirements represent a special use and are to be individually agreed.

Metal ceilings are basically resistant to cold, are good heat conductors and therefore also suitable as heat exchange surfaces (for example for heating and cooling ceilings).

The responsibility for the system's conformity when using other components and/or components from different manufacturers is the responsibility of the respective installation company.

Unless expressly agreed upon, the assured characteristics of the system manufacturer can no longer be maintained when using non-system components.

The installation company is then to be considered as a system manufacturer.

Special requirements

If special requirements due to aggressive liquids, gases or radiation, wind loads, seismic safety, fall protection, reaction to fire, fire resistance or load bearing capacity are to be met, then these requirements have to be specified by the building designer and specially agreed upon.

For large temperature variances the designer shall take into account possible thermal expansion between the membranes and the load bearing substructure of the building.

Colour-coated metal ceilings should avoid being exposed to temperatures exceeding 50° C for long periods, as colour changes may occur depending on the colour shade and coating method used. This is particularly important when installing luminaires that give off high temperatures, as this can lead to overheating and consequently to colour changes in the adjacent membranes.

7.1 Mechanical strength

7.1.1 Fixing to the structure

The possible fixing methods of the system cannot be determined by the system manufacturer due to the different types of structure materials (soffit or wall).

In principle, fixing to the structure shall be in accordance with the guidelines for the European Technical Approval (ETAG) or in accordance with national regulations taking into account multiple fixings.

The maximum distances between the mounting points approved by the system manufacturer shall not be exceeded.

7.1.2 Substructure

Substructure profiles shall be classified in deflection classes in accordance with EN 13964, table 6. The requirements for the flatness of the membrane remain unaffected.

For the permissible load specifications of the hangers and connecting parts, TAIM recommends orientation to the established classes 0.15 kN, 0.25 kN and 0.4 kN with a safety factor of 2.5.

7.1.3 Flexural tensile strength

The flexural tensile strength of membranes is tested in accordance with EN 13964.

7.1.4 Connection of partitions

Partitions shall not be fixed to the metal ceiling or its substructure unless otherwise specified. The building designer shall define the type of partition with the expected load effects on the metal ceiling, as well as the planned type of fixing and coordinate this with the ceiling system manufacturer or the installation company.

Unless stated otherwise, the building designers are responsible for the interface planning and accuracy of the specifications and the installation company for the technical execution.

7.1.5 Expansion joints

The necessity of expansion joints is to be determined by the building designer. Expansion joints are to be considered for metal ceilings.

The constructive design of the ceiling construction shall be determined by the system manufacturer or by the installation company.

Possible thermal expansions between the metal membranes and the load bearing substructure due to temperature differences shall be taken into account by the building designer.

7.1.6 Built-in and built-on elements

Metal ceilings are not designed for the load bearing of built-in or built-on elements without additional measures. Unless otherwise stated, the building designer is responsible for the interface planning and the installation company for the technical execution.

7.1.7 Lay-in or lay-on elements

Lay-in or lay-on elements used in conjunction with metal ceilings are:

- Mineral wool, foam materials etc.
- Tissue, laid-in or glued in

The material specifications are regulated in the relevant product standards and will not be explained here.

When due to the system there is no firm connection of the lay-in or lay-on elements, necessary precautionary measures are to be taken against unintentional release and shall be specified by the building designer.

Lay-in or lay-on elements can influence the behavior of metal ceilings and shall be in coordination with the ceiling system.

For example, if lay-ins with a weight of more than 400 g/m² are used, these ceilings could be considered as special ceilings, the use of the TMMC or parts of the TMMC should then be agreed on a case-by-case basis.

Lay-on elements on the carrier profiles of linear panel ceilings up to 1.5 kg/m² are permitted; or otherwise agreed separately.

Tissues

Tissues are applied to the back of the metal membranes.
Tissues serve to cover perforations and / or sound absorption.

Unless otherwise required

- tissues usually have a basis weight between 50 - 150 g/m²
- tissues can be inserted loosely, with or without mechanical fixings, or
- bonded either to the whole surface or only selective.

Different applications of the tissues at the back of the membrane can cause shadows or cloud formations on the visible side. This depends on the colour of the tissue, the type of perforation and the viewing angle.

This is especially important to consider when using bright and coloured fleece.

Unless otherwise required, tissues are placed on the horizontal back of the membrane.

If perforations are made over the edge of the panel and it is required that the tissue is also to be applied over the edges, then this measure is to be agreed separately.

The use of tissue in wet rooms and exterior is to be agreed separately.

7.1.8 Cutouts

Usually cutouts are made without stiffening upstands and/or stiffening profiles. If there are any requirements, these are to be specified by the building designer.

The building planner must define the type of cutout and the type of fitting and/or surface mounting part and coordinate it with the ceiling system manufacturer.

Applicable dimensional tolerances for cutouts:

Nominal dimension (length / width / diameter, etc.): - 0 / + 2 mm

The flatness tolerances according to EN13964 table 4 do not apply for cutouts.

7.1.9 Wind load resistance

Wind loads are suction and pressure loads that can occur both outside and inside a building. They act both vertically and horizontally and have to be specified by the building designer for the specific building and then taken into account by the system manufacturer.

Substructure and membranes are to be coordinated together.

If required, verifiable static proof shall be provided on the basis of EN 1991-1-4 and national regulations. A preliminary structural design alone is not sufficient to start construction work; it serves only for the cost calculation for the offer. In the case of an order, this has to be specified by the building designer prior to the construction of the ceiling and start of installation.

The installation company issues the warranty.

Interior wind loads

There are no specific requirements in EN 13964, regarding wind loads.

If wind loads $>20 \text{ N/m}^2$ ($> 2 \text{ kg/m}^2$) are to be expected inside the building, then these are to be specified by the building designer.

Exterior wind loads

Suspended ceilings for exterior applications are not covered by EN 13964.

Exterior wind loads can vary depending on the wind zone, geographical location, building type and height, storey height and position of the ceiling.

In practice, there are often only general terms such as "stormproof -" or "windproof suspended ceiling". This information alone does not provide a reliable basis for planning.

The suitability of suspended ceilings for exterior use with regard to wind loads has to be agreed with the system manufacturer.

7.1.10 Impact resistance

If suspended ceilings have to resist impact (e.g. by throwing balls in sports halls), the building designer shall specify the requirements.

Table 9 - EN 13964, table D.1 – Classes of impact velocity

Impact balls	Hand ball	Speed of impact
Classes	1A	$(16,5 \pm 0,8) \text{ m/s}$
	2A	$(8,0 \pm 0,5) \text{ m/s}$
	3A	$(4,0 \pm 0,5) \text{ m/s}$

Requirements for impact resistance shall be tested in accordance with EN 13964 Annex D.

Annex D regulates, among other things, the test setup, the different classes 1A to 3A of the impact speed of the balls, the evaluation and the necessary content of the test report.

Classes 2A + 3A according to EN 13964 may vary depending on the intended use such as gymnastics rooms and swimming pools, certainly have their economic justification and are sufficient to do so.

The EN 13964 gives the examiner a lot of latitude in the evaluation of the ball impact in terms of visual changes ("...appearance shall not have changed to any great degree...").

Measurable parameters for this point are missing, so that not always comparable test results are to be expected here.

Permanent deformations are generally permissible as long as they do not impair the safety and functionality.

7.1.11 Built-in or built-on components

Built-in or built-on components (e.g. luminaires) are also be tested according to EN 13964 for impact resistance requirements.

There are two possibilities for this:

- a) The ceiling system and the built-in or built-on component are jointly tested.
An independent examination of the component can be omitted in these cases.
- b) The built-in or built-on component is tested separately from the ceiling system.
Here are often practical problems as the luminaire manufacturers' test them screwed only on a chip board and these results have no significance for the installation situation. If additional measures are to be taken in the ceiling system then these shall be agreed separately.

Similar types of tested installed components (up to their maximum dimensions) can be installed without additional testing.

Unless stated otherwise, the building planner is responsible for the reliability of the interface planning and the installation company for the professional execution.

Built-in components without load bearing connection to the ceiling system

The installed components are fastened to the soffit independently, without a load-bearing connection to the impact resistant ceiling.

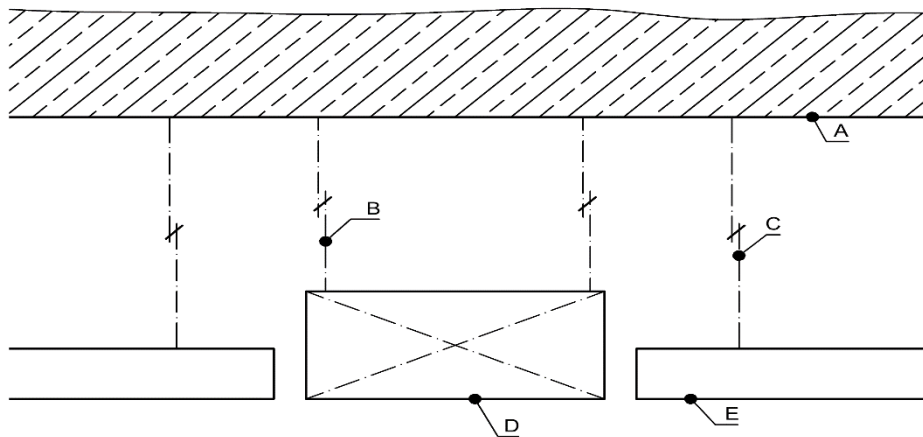

- A = Soffit
- B = Suspension hanger
- C = Impact resistant suspension
- D = Impact resistant built-in component
- E = Impact resistant ceiling

Fig. 60 – Example for an impact resistant ceiling with built-in component without load bearing connection to the ceiling system

Built-in components with load bearing connection to ceiling system

The installed components are fastened in combination with the load-bearing parts of the impact-resistant system ceiling.

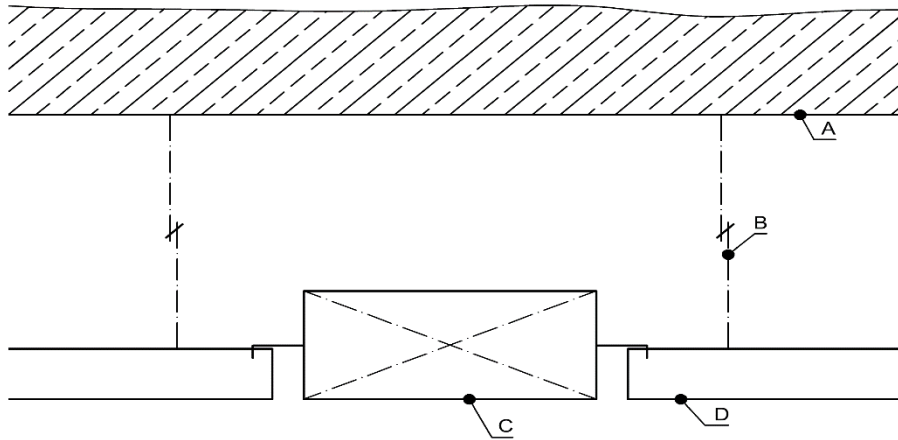

- A = Soffit
- B = Suspension for the impact resistant ceiling
- C = Impact resistant built-in component
- D = Impact resistant ceiling

Fig. 61 – Impact resistant ceiling with installed built-in component and load-bearing connection to the ceiling system

7.1.12 Seismic resistance

If seismic resistance is required, it shall be specified by the building designer.

The EN 1998 “Eurocode 8: Design of structures for earthquake resistance” has to be considered for the structural design of the ceiling.

7.2 Materials

In addition to the steel and aluminum materials specified in EN 13964, metal ceiling systems in stainless steel according to EN 10088-2 are also acceptable.

Other metals are possible in coordination with the respective system manufacturer.

7.3 Dimensions and tolerances for membranes

The following tolerances apply to rectangular, flat formats. Different geometries and shapes are to be agreed separately.

These tolerances apply to non-perforated and perforated membranes with a perforation diameter $\leq 4\text{mm}$, open area $\leq 25\%$ and with unperforated edges of at least 5 mm.

If the perforation goes over the edges, the tolerances have to be specified separately.

For cutouts, the flatness tolerances according to EN 13964 or TAIM do not apply.

When measuring length and width tolerances, the visible side should be considered.

Inlays up to 400 g/m^2 are permitted without any effect on flatness.

Inlays (e.g. gypsum plasterboard) with a weight per unit area greater than 400 g/m^2 or installations (e.g. recessed luminaires, ventilation outlets), components (e.g. loudspeakers, luminaires, smoke detectors, way finders) or composite elements are only permitted in agreement with the system manufacturer as these can influence both the deflection and the structural engineering of the entire ceiling system.

Different panel dimensions and/or different inlays/lay-ons or even difference between passive and cooling elements can lead to different deflections.

Due to unfavourable lighting conditions, e.g. grazing light, it is not always possible to exclude an emerging of the heat conducting profiles at the visible side of the membrane.

Raw material and/or production-related waves may occur in the visible surface of the ceiling.

Tensions caused during the perforation process can act on the panel, causing deformations of the flatness of the upstands.



Height variations between individual panels are permitted provided that the panels do not exceed the allowed flatness tolerances.

The tolerances of membranes with pressed surfaces and special coatings, such as e.g. tissue on the visible side, are to be agreed upon individually.

Constrictions may occur in the middle of the membrane, especially in the case of large-format membrane components.

7.3.1 Metal membranes and tiles

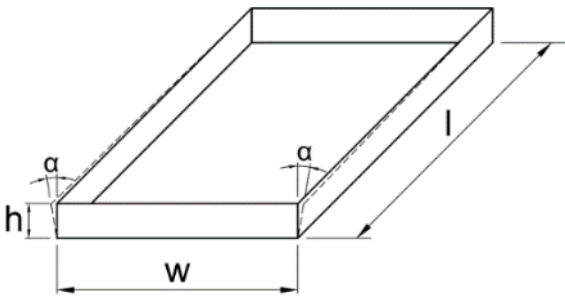
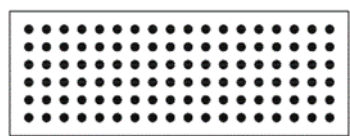
Table 10 –Tolerances for metal membranes and tiles

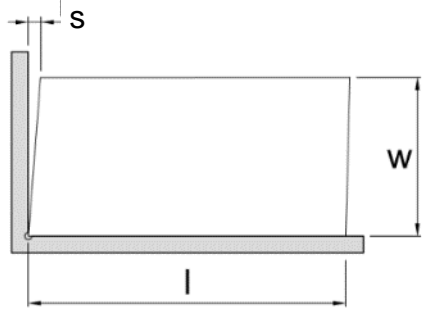
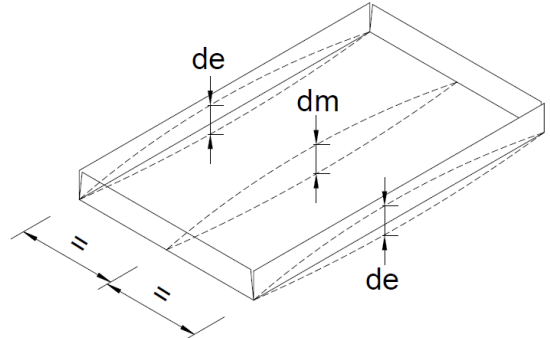
Length l: - for lengths ≤ 1.000 mm $+0 / - 0,5$ mm - for lengths > 1.000 mm $+0 / -0,4$ mm/m						
Width w: $+0 / -0,4$ mm						
Upstand angularity α : $\leq \pm 5^\circ$ System-related deviations are possible						
Unperforated edges: at the long sides $\pm 0,9$ mm at the short sides $\pm 0,5$ mm/m						
Height functional upstand h: $\pm 0,3$ mm						
Squareness s: - for widths ≤ 625 mm $\pm 0,5$ mm - for widths > 625 mm $\pm 0,6$ mm						
Deflection d: d_m = deflection membrane middle d_e = deflection membrane edge						
w [mm] \ l [mm]	$l \leq 1.000$		$1.001 < l \leq 2.000$		$2.001 < l \leq 3.000$	
	d_e	d_m	d_e	d_m	d_e	d_m
$w \leq 400$	$\pm 0,5$	-0,2 +3,0	-0,5 +1,5	-0,2 +4,0	-0,5 +3,0	-0,2 +6,0
$400 < w \leq 500$		-0 +4,0		-0 +5,0	-0,5 +3,5	-0 +7,0
$500 < w \leq 625$		-0 +6,0		-0 +7,0	-0,5 +4,0	-0 +9,0
> 625		-0 +10,0		-0 +13,0	to be agreed	

7.3.2 Linear panels and single-walled baffles

Table 11 –Tolerances for linear panels and single-walled baffles (where applicable)



Length l:																							
850 < l ≤ 3.000 mm		±1,0 mm																					
3.000 < l ≤ 6.000 mm		±1,5 mm																					
Width w: ± 0,5 mm																							
Height h: ± 0,3 mm																							
Angularity upstands α: ± 5°																							
Due to material- and production properties additional spring-back tolerances α _e at both ends (≤150 mm from the end) may occur:																							
α _e ≤ ± 6°/per side or 0,1 x height h																							
					<table border="1"> <thead> <tr> <th>h [mm]</th> <th>α_e [mm]</th> <th>w + 2 x α_e [mm]</th> </tr> </thead> <tbody> <tr> <td>12,5</td> <td>1,25</td> <td>w + 2,5</td> </tr> <tr> <td>15,5</td> <td>1,55</td> <td>w + 3,1</td> </tr> <tr> <td>24,5</td> <td>2,45</td> <td>w + 4,9</td> </tr> <tr> <td>28,5</td> <td>2,85</td> <td>w + 5,7</td> </tr> <tr> <td>38,5</td> <td>3,85</td> <td>w + 7,7</td> </tr> </tbody> </table>	h [mm]	α _e [mm]	w + 2 x α _e [mm]	12,5	1,25	w + 2,5	15,5	1,55	w + 3,1	24,5	2,45	w + 4,9	28,5	2,85	w + 5,7	38,5	3,85	w + 7,7
h [mm]	α _e [mm]	w + 2 x α _e [mm]																					
12,5	1,25	w + 2,5																					
15,5	1,55	w + 3,1																					
24,5	2,45	w + 4,9																					
28,5	2,85	w + 5,7																					
38,5	3,85	w + 7,7																					
Camber c: ≤ 0,6 mm/m																							
Deflection d _m and d _e																							
w [mm]	w ≤ 100	100 < w ≤ 200	200 < w ≤ 300	300 < w ≤ 400																			
d _m [mm]	- 1,0 + 1,5	- 1,25 + 2,0	- 1,5 + 2,5	- 1,75 + 2,7																			
d _e [mm]	± 1,5	- 2,5 + 2,0	- 3,5 + 2,5	- 4,0 + 2,7																			
Special requirements for the deflection at the linear panel ends are to be specified by the building designer.																							
Ripple r:																							
w [mm]	0-200		201-400																				
r [mm]	± 0,25		± 0,4																				
Due to material and production properties ripples may can occur on the face side.																							

Table 12 – System tolerances linear panel ceilings

<p>Support profile module: ± 0,05 mm / module</p>	 <p>1 = module tolerance 2 = module 3 = support profile 4 = length tolerance 5 = cutting loss 6 = support profile length = x times module minus cutting loss 7 = module length support profile</p>
<p>Support profile length: The length of the support profiles results from the number of support profile modules including module tolerances minus a length difference to be named by the manufacturer (cutting tolerance). The manufacturer begins and ends each support profile in the joint of the punched module. The module dimensions are guaranteed over several support profiles through a support profile splice or an assembly instruction specified by the manufacturer.</p>	
<p>System height h_s: ± 1,0 mm</p>	 <p>1 = h_s 2 = support profile 3 = linear panel</p>
<p>Linear panel deflection between 2 support profiles: $1/500 \times$ support profile distance</p>	 <p>1 = linear panel 2 = support profile</p>

7.3.3 Expanded metal ceilings

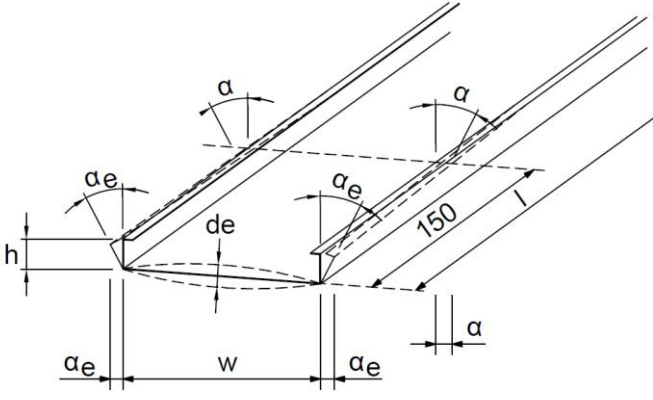
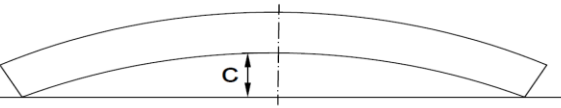
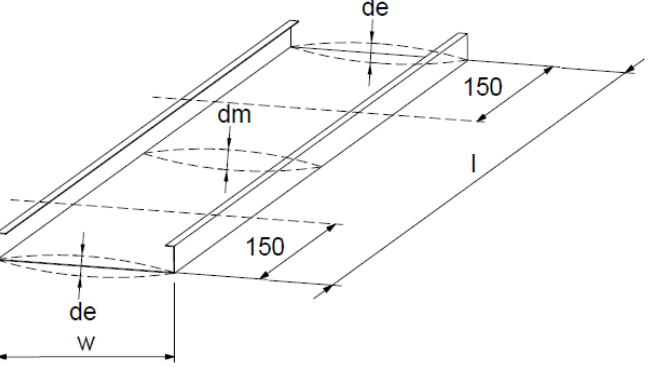
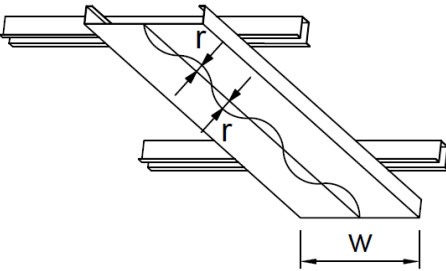
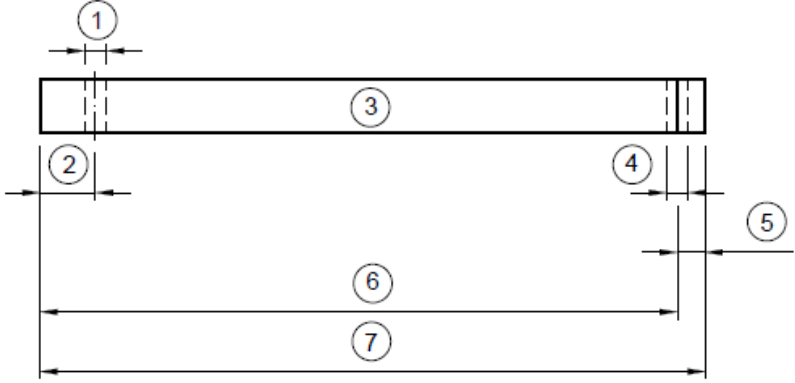
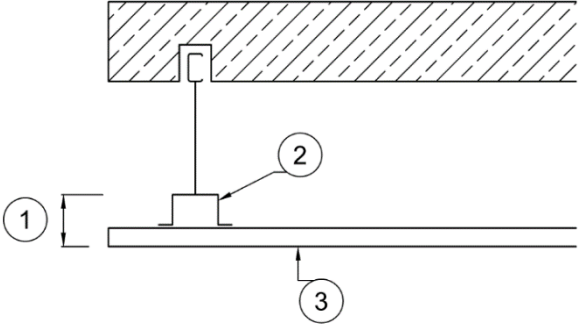
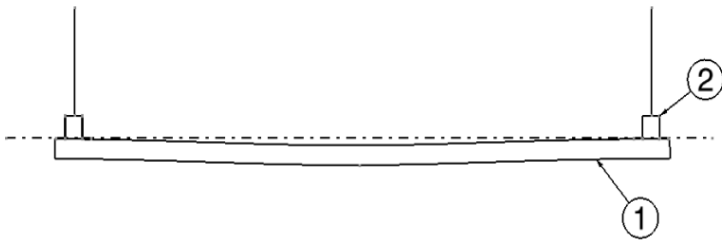
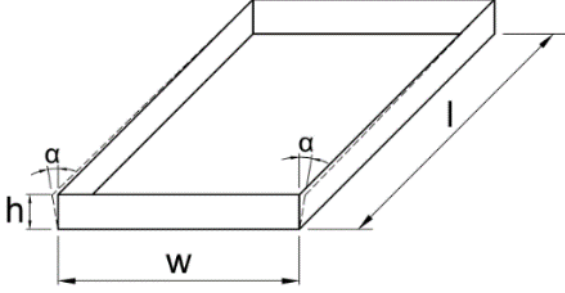
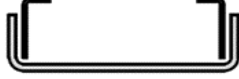
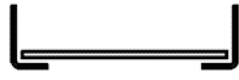
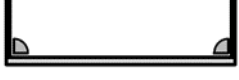
Table 13 – Tolerances for expanded metal ceilings^{a)}

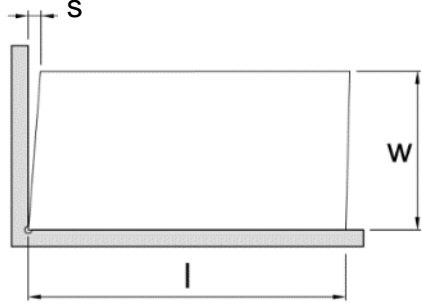
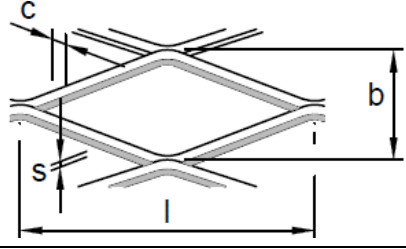
Membrane shape	Length / Width [mm]		
	≤ 1.000	1.001- 3.000	
External mesh	+0 -5	+0 -8	
Internal mesh	+0	+0	
External frame	-3	-5	
Inlay meshes	+0 -3	+0 -3	
<p>Height of functional upstand h / upstand angularity α:</p> <p>The tolerances of the functional upstands are to be agreed on a case by case basis due to the variety of mesh variants and design possibilities.</p>			
<p>Squareness s:</p> <p>- for widths ≤ 625 mm ± 2,0 mm</p> <p>- for widths > 625 mm ± 3,0 mm</p>			
<p>The deflection of expanded metal membranes depends on their dimensions, material, type of mesh, mesh width, material thickness and possible inlays.</p> <p>Permissible tolerances of deflection are therefore to be agreed individually.</p> <p>Wavy deformations can also occur due to the production process.</p>			
<p>Mesh tolerances:</p> <p>b = mesh width ± 5%</p> <p>l = mesh length ± 5%</p> <p>c = strand width ± 5%</p> <p>s = strand thickness ± 10%</p>			
<p>a) The specified tolerances apply to mesh widths ≤ 25 mm, mesh lengths ≤ 65 mm and web thicknesses ≤ 1.5 mm. For larger meshes, the tolerances are to be agreed individually.</p>			

7.3.4 Baffle ceilings

Table 14 – Tolerances for baffles

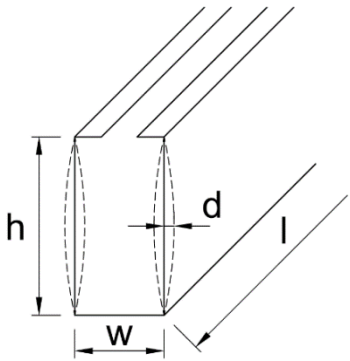
Length l:		
500 mm $\leq l \leq$ 1.500 mm	+ 0 / - 1 mm	
1.500 mm $< l \leq$ 3.000 mm	+ 0 / - 1,5 mm	
Width w:		
25 mm $\leq b \leq$ 50 mm	\pm 1,5 mm	
Height h:		
75mm $\leq h \leq$ 300 mm	\pm 1,5 mm	
Deflection d:		
75mm $\leq h \leq$ 300 mm	\pm 3 mm	
Unperforated edges:		
at the long sides	\pm 0,9 mm	
at the short sides	\pm 0,5 mm/m	
<p>The dimensional tolerances for baffles made of extruded aluminum profiles apply to EN 12020-2, baffles made from corrosion resistant steel profiles apply to EN 10088-3.</p>		

7.3.5 Open cell ceilings

Table 15 – Tolerances for open cell ceilings

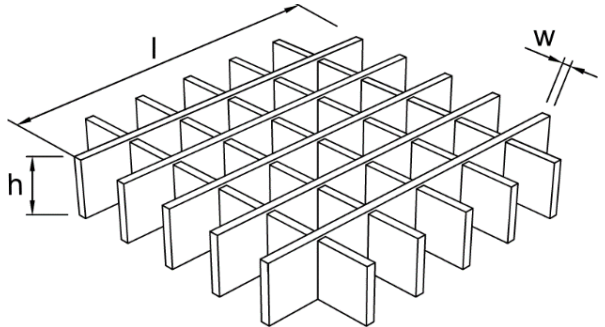
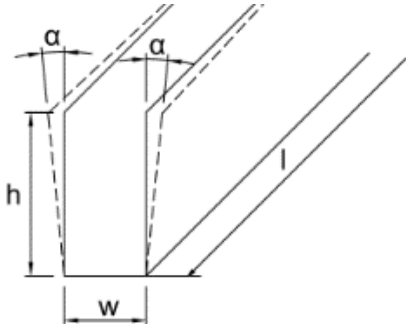
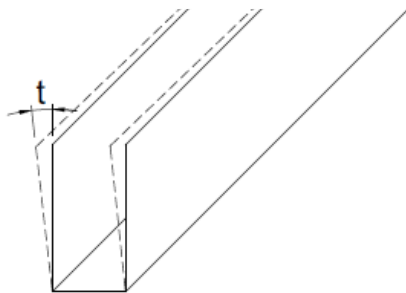
Length l:		
600 mm $\leq l \leq$ 3.600 mm	+ 0,8 / - 1,0 mm	
Width w:		
3 mm $\leq b \leq$ 20 mm	+0 / - 0,5 mm	
Height h:		
20mm $\leq h \leq$ 60 mm	\pm 0,3 mm	
Spring-back at profile end α :		
$\alpha \leq 6^\circ$, however $t \leq 5$ mm The profiles can be slightly V-shaped depending on manufacturer. Due to material- and production properties, additional spring-back tolerances may occur at the profiles ends.		
Twisting t:		
$t \leq 2^\circ/\text{m}$, however $t \leq 3$ mm over the total length		

7.4 Safety in case of fire

Requirements for fire protection (reaction to fire - fire resistance) are regulated by law and may additionally be required from private law agreements (e.g. insurance).

Fire protection requirements for components are amongst others subject to building classification and the type of use of the buildings, who are to be determined by the building planner on the basis of the fire protection concept.

Metal ceilings conforming to TMMC are particularly suitable for meeting the fire resistance and reaction to fire requirements.

These require a valuation from the building planner for use depending on the construction situation.

7.4.1 Reaction to fire

The European classification of the reaction to fire of construction products is regulated in EN 13501-1. The test method also takes into account information on flaming droplets and the smoke production, who are criteria in the building material classification.

Metal ceilings are depending on the type, "non-flammable" or "fire retardant".

With today's know how with regard to coatings and possible inlays, these so-called composite materials can be produced as a "non-flammable" product. Such composite metal ceiling shall be tested and classified as complete elements.

Metal ceilings are classified as a harmonized construction product (product standard EN 13964) and shall therefore be tested and classified in accordance with EN 13501-1.

National reaction to fire test certificates shall be taken into account when using unregulated construction products.

7.4.2 Fire resistance

The European classification for fire resistance of building elements is regulated in EN 13501-2.

Metal ceiling systems shall be tested as a building element (meaning kit in the sense of EN 13964) with regard to fire resistance, which is representative of the complete ceiling system (suspension, substructure, membrane, etc.).

The result is documented in a classification report (European use verification).

National use verifications for fire resistance shall be considered.

7.4.3 Smoke leakage

Smoke leakage requirements for suspended ceilings shall be met in conjunction with the required resistance to fire in accordance with EN 13501-2.

A separate normative test procedure for the smoke-leakage either of "suspended ceilings with fire resistance" or for "suspended ceilings without fire resistance" does not exist.

If there are requirements for smoke leakage, these have to be agreed separately.

[National annex Germany](#)

7.5 Heated and cooling ceiling systems

Standard metal ceiling systems are not readily suitable for the use as heating and cooling ceilings. The coordination of and interaction between the individual components for a well-functioning heating and cooling ceiling requires extensive expertise, project-specific planning and precisely manufactured components. The cooling capacity is measured and reported according to EN 14240, the heating capacity according to EN 14037.

The design of the heating and cooling ceiling system shall be selected by the manufacturer in such a way that the specific heating/cooling capacities comply with the technical standards mentioned above. All water-carrying tubes and connecting parts shall be resistant against oxygen-diffusion in accordance with ISO 17455.

In order to avoid condensation resulting in mold formation or corrosion, the building planner shall make provisions for a dew point control system.

System leakage tests are recommended according to EN 1264-4.

The test pressure is twice the operating pressure, but min 6 bar. The test pressure shall be maintained for 24 hours.

7.6 Electrical safety

Metal ceiling systems are not earthed as standard and not equipped with an electric shock-proof design. However, they can basically be prepared for installing electrical devices.

If metal ceiling systems or individual parts thereof must be earthed due to site regulations, the requirements and test conditions are to be agreed upon in advance.

Relevant requirements and test conditions - including possibly connection devices - are always to be additionally agreed upon with the building planner.

The necessity of such equipment shall be checked by the client or his specialist planner and implemented accordingly. The responsibility for the electrical safety of the metal ceiling systems remains with the client.

7.7 Hygiene, health and environment – Toxic gasses and dangerous substances

7.7.1 Hygiene

Metal ceilings are suitable for use in areas with hygienic requirements due to their smooth, dust-free surfaces.

The surfaces can be disinfected with common disinfectants.

Due to the large number of available disinfectants, it is recommended to agree specific requirements and application with the system manufacturer.

The term “hygiene ceiling” is not a standardized term. It is recommended that the requirements for the metal ceiling are clearly specified by the building planner.

7.7.2 VOC – Volatile organic compounds

With the test standard EN 16516: "Construction Products - Assessment of Release of Hazardous Substances - Determination of Emissions to Indoor Air" published in 2018, there is meanwhile a European uniform horizontal reference method for determining the release of regulated hazardous emissions from construction products to indoor air.

However, what is still missing is an EU-wide harmonized assessment scheme for VOC emissions from construction products.

In order to assess a possible health risk, the individual values of relevant substances of concern or toxicity should always be taken into account in addition to the total of volatile organic compounds (TVOCs).

Due to this lack of uniform EU-wide guidelines, TAIM recommends applying the national evaluation scheme until further notice:

- In Germany, the data are evaluated and classified into classes according to AgBB (Committee for the Health Assessment of Construction Products).
- France and Belgium also have their own national VOC labels with - though sometimes differently defined - limits for selected substances.

In addition, there are already several voluntary certification marks based on EN 16516, e.g. from the DGNB (German Sustainable Building Council).

Unless otherwise requested, TAIM recommends the verification according to the AgBB guidelines.

7.7.3 Susceptibility to the growth of harmful micro-organisms

There are ceiling systems made of non-metallic materials that contain organic components and thus may provide breeding grounds for micro-organisms.

Metal ceiling systems are made of metallic materials and thus provide no breeding ground for the growth of micro-organisms. Only the surface coating and possibly existing inlays or lay-ons may contain organic components.

If the options for cleaning or disinfection (see section 7.7.1) are not sufficient, the surface coating can be executed antibacterial in coordination with the system manufacturer.

There is no established assessment procedure so far for this criterion in EN 13964.

If there are requirements, these shall be specified by the building designer.

7.8 Acoustics

The requirements for acoustics are specified in EN 13964.

Requirements for the minimum sound insulation can be found in the respective national regulations or may also result from private law agreements.

Metal ceilings according to TMMC are suitable for meeting such requirements; requirements are to be specified by the building planner.

Unless otherwise expressly stated by the manufacturer, the mentioned acoustics declaration is based on laboratory values.

7.8.1 Airborne sound insulation

The results of laboratory tests can be transferred to ceilings of similar design without re-testing under the following conditions:

Changes must not lead to a deterioration of the acoustic performance (e.g. inlays with a higher thickness, differing density or dynamic rigidity).

In cases of doubt, the equivalence shall be verified by a notified testing laboratory.

7.8.2 Sound absorption

The required sound level reduction and the arrangement of the sound absorbing surfaces depend on a number of factors.

These factors include the type of use of the room, the type of generated noise, the need to regulate the reverberation, and the reflective properties of the periphery surfaces.

The required reverberation time according to EN ISO 354 as well as the type, quantity and layout of the acoustical ceiling systems are to be defined by the building designer.

Conversions to ASTM C423 (NRC and/or SAA) parameters are permitted.

The sound absorption coefficient shall at least be expressed in octaves (α_p -practical sound absorption coefficient) and converted into a weighted sound absorption coefficient (α_w as a single value according to EN ISO 11654), indicating the parameters where appropriate.

Ceiling islands represent single absorbers from an acoustic point of view.

Due to the usually peripheral openness of the ceiling island, there is additional absorption at the rear of the island. Consequently, it should be noted that the specification of the test results is only permitted in conjunction with the tested parameters (e.g. suspension height, format of the ceiling island).

Therefore, the equivalent sound absorption area is recommended for the determination of sound-absorbing properties.

7.9 Durability - Corrosion protection

Metals, alloys and metallic coatings can corrode in humid atmospheres.

A variety of national and international standards and regulations define requirements for corrosion protection.

7.9.1 Corrosivity categories / Exposure classes

Established corrosion protection standards follow the classification into corrosivity categories according to EN ISO 9223 from C1 (very low) to CX (extreme) for the specification of the required corrosion protection measures.

EN 13964 does not follow this classification, but defines exposure classes from A to D.

The following tables establish a relationship between the exposure classes according to EN 13964 and the corrosivity categories according to EN ISO 9223 and give examples of typical environmental conditions:

Table 16 – Comparison exposure classes and corrosivity categories

Exposure class acc. to EN 13964	Corrosivity category acc. to ISO 9223	
	Category	Corrosivity
A	C1	Very low
B	C2	Low
C	C3	Medium
D	C4	High
	C5	Very high
	CX	Extreme

The required corrosivity category or exposure class has to be specified by the building planner.

Table 17 - Typical atmospheric environments related to the estimation of corrosivity categories

Corrosivity category acc. to ISO 9223	Examples for typical environments		Typical Temperature- and humidity conditions
	Outdoor	Indoor	
C1	Not suitable	Heated spaces with low relative humidity and insignificant pollution, e.g. offices, showrooms, schools, museums	max. 30°C max 70% relative humidity no risk of condensation no corrosive impurities
C2	Low pollution, e.g. rural areas, small towns	Unheated spaces with low frequency of condensation, e.g. storage, sport halls	max. 30°C max 90% relative humidity low condensation risk low corrosive impurities
C3	City and industrial atmosphere with moderate air pollution and without direct weathering, e.g. suspended ceilings on canopies, gas station roofs and underground car parks	Spaces with moderate frequency of condensation and moderate pollution from production process, e.g. food-processing plants, laundries, breweries, dairies, shower areas of sport halls	max. 30°C max 95% relative humidity moderate condensation risk moderate corrosive impurities
C4	Industrial areas with high air pollution and/or coastal areas with moderate effect of chlorides	Spaces with high frequency of condensation and high pollution, e.g. industrial processing plants, swimming pools without salt pollution	Swimming pool climate: max. 40°C max. 70% relative humidity max. 0,5% NCl ₃ high condensation risk high corrosive impurities
C5	Atmospheric environment with very high pollution and/or significant corrosive impurities, e.g. industrial areas, coastal areas with significant effect of chlorides	Spaces with very high frequency of condensation and/or with high pollution, e.g. swimming pools with salt pollution	Very high condensation risk Very high corrosive impurities
CX	Atmospheric environment with very high pollution and/or almost permanent condensation, e.g. offshore areas	Spaces with almost permanent condensation or extensive periods of exposure to extreme humidity effects and/or with high pollution.	Almost constant condensation high corrosive impurities

The information in this table partially differs from the examples in ISO 9223, as preferred examples for suspended ceiling applications are given here.

7.9.2 Durability range

In addition to functional requirements, metal ceilings usually also have aesthetic requirements. Therefore, when determining the permissible extent of damage to the coating before the first major maintenance measure, it may make sense to differentiate between invisible (substructure - usually only functional requirements) and visible (membranes - additional aesthetic requirements) components. From a functional perspective, the first major anti-corrosion maintenance measure is usually required when around 10% of the coatings have a Ri 3 degree of rusting according to ISO 4628-3.

From an aesthetic point of view, even minor damage is usually disruptive.

Particularly in the case of coil-coated components made of un-/low-alloyed steel, it should be taken into account that the cut edges are usually not coated and therefore there is only limited corrosion protection.

The permissible extent of damage to the coating before the first major anti-corrosion maintenance measure has to be agreed between the contractual partners.

Metal ceilings are generally very easy to access and can also be inspected, so that any necessary anti-corrosion maintenance measures can be carried out easily.

The building planner and/or operator is responsible for determining and implementing the necessary controls.

7.9.3 Testing procedure

The suitability of a corrosion protection system for a specific corrosivity category and durability range is usually proven using artificial aging tests in the laboratory. Compared to outdoor weathering tests and/or practical experience, which often take several years, laboratory tests have the great advantage that the test results are usually available within a few weeks.

However, the artificial aging tests cannot take into account all factors that (may) occur in practical use. Due, among other things, to the manageable test duration, laboratory tests have established themselves on the market as a common proof of suitability for corrosion protection.

It should be taken into account that different test methods and test durations are state of the art for the two most common material groups in the metal ceiling sector (continuously galvanized un-/low-alloyed steel and aluminum).

The following table provides an overview of the recommended test procedures and test durations for these two material groups.

For other material groups, the required proof of corrosion protection has to be agreed between the contractual partners on a case-by-case basis.

Table 18 - Test procedures and test durations depending on the corrosivity category for a durability range of 15-25 years

Corrosivity category acc. to table 16	Un-/low-alloyed steel with organic coating		Galvanized un-/low-alloyed steel with organic coating	Aluminum ^{a)}	
	EN ISO 6270-2 (Condensation of water) h	EN ISO 9227 NSS (neutral salt spray) h	EN ISO 6270-2 (Condensation of water) h	EN ISO 6270-2 (Condensation of water) h	EN ISO 9227 AASS (acetic acid salt spray) h
C1	--	--	--	--	--
C2	120 ^{b)}	--	120 ^{b)}	--	--
C3	240	480	240	--	--
C4	480	720	480	1.000 ^{b)}	1.000 ^{b)}
C5	720	1.440	720	1.000 ^{b)}	1.000 ^{b)}
CX	To be agreed on a case-by-case basis				

a) For aluminum, the relevant test standards (DIN 17611 / EN 1396 / EN 12206-1 / ISO 7599) define further test methods, which have been omitted here for reasons of clarity. If complete proof is required according to the respective standard, this has to be agreed between the contractual partners.

b) No testing is required when selecting suitable coating systems according to table 19.

Table 19 - Minimum requirements for corrosion protection

Corrosivity category acc. to table 16	Un-/low-alloyed steel	Aluminum
	Coating system ^{a)}	Coating system ^{a)}
C1	Products made of continuously hot-dip coated steel according to EN 10346, made of electro galvanized steel according to EN 10152, made of coil-coated steel according to EN 10169 CPI1 or RC1, Threaded rods according to DIN 976-1 with galvanic zinc coating $\geq 5\mu\text{m}$ according to EN ISO 2081 or Wire according to EN ISO 16120-2 with zinc coating class D according to EN 10244-2	No corrosion protection required
C2	Products made of continuously hot-dip coated steel according to EN 10346, made of electro galvanized steel according to EN 10152 without or with an additional organic coating as follows: ZE25 / 25 + 40 μm per side, ZE50 / 50 + 20 μm per side or ZE100 / 100 without organic coating, made of coil-coated steel according to EN 10169 CPI2 or RC2, threaded rods according to DIN 976-1 with galvanic zinc coating $\geq 8\mu\text{m}$ according to EN ISO 2081 or wire according to EN ISO 16120-2 with zinc coating Class C according to EN 10244-2	
C3	Free choice of coating Test acc. to table 18	Anodised products according to DIN 17611 class 15, anodized products according to EN ISO 7599 class AA 15, coil coating according to EN 1396 Corrosion resistance index 1 or powder coating according to EN 12206-1
C4		Anodised products according to DIN 17611 class 20, anodized products according to EN ISO 7599 class AA 20, coil coating according to EN 1396 Corrosion resistance index 2 or powder coating according to EN 12206-1
C5		Anodised products according to DIN 17611 class 25, anodised products according to EN ISO 7599 class AA 25 or coil coating according to EN 1396 Corrosion resistance index 3
CX		To be agreed on a case-by-case basis

a) Equivalent materials in combination with an equivalent corrosion protection, which leads to a similar degree of protection, are allowed.

For stainless steel - which is usually used without coating - the test methods according to table 18 are not suitable. EN 1993-1-4 and, in addition, the national technical approval (abZ) No. Z-30.3-6 from DIBt (Deutsches Institut für Bautechnik) define suitable alloys made of stainless steels (products, fasteners and components) for various applications.

Fasteners such as screws, rivets, etc. must be used with at least equivalent corrosion protection. It is preferable to use connecting elements made of suitable stainless steels (see EN 1993-1-4 and abZ No. Z-30.3-6).

When combining different materials, there is a risk of bimetallic corrosion (contact corrosion).

7.9.4 Test specimen

The tests have to be carried out on representative, fully formed test specimen, as used in practice. To reduce the testing complexity, existing component tests can be transferred to components with similar geometry and the same coating system.

In principle, the most critical components from a corrosion protection perspective always have to be used for the test (smallest bending radii, etc.).

For example, Nonius components of different lengths can be combined. For membrane components, the smallest and largest perforations have to be tested; this means that all intermediate perforations are covered. Profiles, e.g. U, UA, UD and UW profiles with different widths, heights and sheet thicknesses can be combined.

The representative samples and associated comparable samples have to be agreed with the testing laboratory and documented accordingly in the test report.

The samples have to correspond to the series production and coating.

For each suitability test at least 3 test specimens and for fasteners at least 10 test specimen have to be tested.

7.9.5 Assessment of corrosion protection systems

All test results refer to independent laboratory tests; these can differ from the local corrosion loads at real environmental conditions.

When evaluating according to the artificial aging tests defined in Table 18, at least 2 out of 3 or, in the case of fasteners, 8 out of 10 test specimen have to meet the following requirements.

When testing coil-coated components, the cut edges bordering the component are not evaluated up to a distance of 10mm from the edge.

Table 20 - Evaluation of the test specimen after the artificial aging tests for coating systems on non-/low-alloyed steel^{a)b)}

Assesment method	Testing standard	Requirements	Assessment time
Degree of blistering	EN ISO 4628-2	Membranes: 0 (S0) Components: 2 (S2)	Immediately
Degree of rusting	EN ISO 4628-3	Ri 0	
Degree of cracking	EN ISO 4628-4	0 (S0)	
Degree of flaking	EN ISO 4628-5	0 (S0)	
Cross-cut test ^{c)}	EN ISO 2409	classification 0 to 2	Assessment after 7 days conditioning acc. to EN 23270

a) The assessment of aluminium is done acc. to the respective test standard (DIN 17611 / EN 1396 / EN 12206-1 / ISO 7599)

b) For fasteners, only the degree of rusting can be assessed

c) Only applicable for test specimen with a correspondingly large test surface

7.10 Coatings

7.10.1 Coating processes

For metal ceilings, the following coating methods and types are common:

Table 21 – Coating processes

Coating type	Coating process			
	Coil coating		Individual coating	
	Aluminium	Carbon steel	Aluminium	Carbon steel
Powder coating	EN 1396	EN 10169	EN 12206-1	---
Coil coating	EN 1396	EN 10169	---	---
Anodising	DIN 17611 ISO 7599	---	DIN 17611 ISO 7599	---
Electrolytically zinc coating	---	EN 10152	---	ISO 2081
Hot dip galvanising	---	EN 10346	---	ISO 1461
Other methods, e.g. digital printing or plastics film	EN 1396	EN 10169	---	---

With coil coating the finish is always applied before forming and/or perforation, with individual coating the surface of the finished product is coated.

Unless otherwise specified or required (e.g. for corrosion protection reasons), all membranes are coated only on one sided – i.e. the side facing the room.

Substructure components and back side of the membranes are usually not coated.

Unless otherwise stated, with individual coating, only the edges of the membranes that are visible in the joint are coated.

If the installation direction has an influence on the visual appearance, this shall be marked by the system manufacturer and taken into account during installation or during tests.

This occurs especially in perforated and on irregular surfaces.

For hot-dip galvanizing according to EN ISO 1461 of e.g. expanded metal zinc droplets may occur.

By design, the substructure may be visible, e.g. with expanded metal ceilings and ceiling islands.

A coating of the substructure for visual reasons is to be agreed separately.

7.10.2 Coating thickness

The thickness of the coating depends on the different coating methods.

A uniform coverage of the substrate and adherence to the surface tolerance (including colour and gloss) shall be warranted.

Possible methods for measuring the layer thickness on metallic substrates are defined in EN ISO 2808.

7.10.3 Colours / Colour deviations

Explicit specification of a colour, through indicating a single particular RAL or NCS colour is not adequate as even the defined colour cards are subject to tolerance fluctuations. Unless otherwise agreed, the manufacturer's specifications apply to its colour palette.

In the case of necessary colour and gloss level adjustments, TAIM recommends a design based on A4 sample sheets.

If the colour samples are agreed upon, they shall be kept at least until the building hand over.

The colour difference is measured with the CIE-Lab method according to EN ISO 11664-4.

The permissible tolerances are basically to be distinguished between white shades and colourful shades:

For white shades, a colour deviation $\Delta E \leq 1.0$ is allowed.

For colourful shades larger deviations are acceptable.

Metallic paints and other effect surfaces cannot be assessed with the usual measuring equipment. Here is a purely visual colour comparison executed.

The different colour effects of metallic powder coatings are defined by the distribution and orientation of the metallic pigments in the powder film.

Due to the different orientation of these pigments, the colour may change depending on the perspective.

This is particularly noticeable by the human eye when the support material (e.g. the ceiling panel) is rotated and/or the angle of the light incidence changes (so-called colour and/or brightness contrast), or when unperforated and perforated ceiling membranes are installed next to each other (example: unperforated post cap - perforated ceiling membrane).

The reason for this is the different surface structure due to the perforation and the associated different refraction and reflection of light. Such physical conditions cannot be influenced by the coater and do not constitute a reason for complaint.

For later deliveries after longer periods larger colour deviations shall be accepted. The same applies if, due to changed technical conditions (e.g. new environmental protection laws), an additional delivery of the same colour is not possible.

For colour-coated metal ceilings, constant temperatures above 50 ° C should be avoided, as colour changes may occur depending on the colour shade and coating method used. This is especially important when installing luminaires that emit high temperatures, as they may cause overheating when in use which may cause colour changes in the adjacent membranes.

7.10.4 Gloss

The gloss value is determined according to EN ISO 2813.

Tolerance specifications are defined as follows, depending on the 3 different gloss ranges:

Matt	(0 - 30 GU)	± 4 GU Deviation
Medium gloss	(31 - 70 GU)	± 5 GU Deviation
High gloss	(71 - 100 GU)	± 6 GU Deviation

GU = Gloss units

7.10.5 Light reflectance

When specifying the light reflectance, usually the total reflection (= sum of directional and diffuse reflection) is meant.

The light reflectance value (LRV) indicates the percentage of light reflected from the surface.

The reflection capacity of the surface is measured either by means of a sphere-type spectrophotometer or by means of a goniphotometer.

Both measuring principles consider different measuring angles and the distinction between total reflection, directional reflection and diffuse reflection (= light scattering due to the surface roughness).

Product-independent European or international standards for reflection measurement are currently not available. The ISO 7724-2 and ISO 7724-3 mentioned in EN 13964 have been withdrawn without replacement.

For aluminum surfaces, the total and diffuse reflectance is measured according to EN ISO 6719, and the measurement of the directed reflectance according to EN ISO 7668.

For other surfaces TAIM recommends to use the measuring method according to DIN 5036-3.

In the case of light reflection, the influence of the perforation and the inlay on the reflectance is to be considered.

7.10.6 Perforations

The selection of the visible perforation pattern depends on architectural and acoustic requirements.

The description of the different perforation patterns can be found in the information provided by the system manufacturer.

The unperforated edge depends on the perforation pattern and can be different on the long and short side.

For different panel lengths, the unperforated edge at the faces may be different in appearance and different in width.

For small perforations <3 mm and small perforation spacing or large free area perforation, moiré effects may occur which may be visible in light-dark shading.

Description

The description of the type of perforation and the perforation pattern is made either in accordance with DIN 24041 or according to the manufacturer.

Table 22 – Examples of perforation types



Common perforations		
Abbreviation	Description	Example
R	Round perforations	
L	Elongated perforations	
Q	Square perforations	

Table 23 - Examples of perforation patterns

Common perforation patterns		
Abbreviation	Description	Example
g	Straight row of perforations (90°)	
d	diagonal row of perforations (45°)	
v	diagonal row of perforations (60°)	

Example: $Rv-1.8-20$

diagonal row of perforations 60° Perforation diameter in mm open area in %

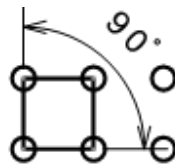
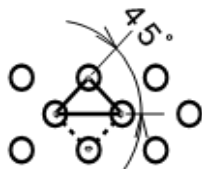
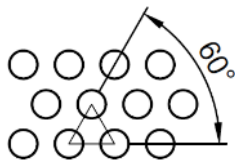
Open area

The open area refers to the perforated surface with the nominal size of the perforation. Depending on the coating method, the actual perforation diameter may differ from the specified diameter, so the open area may also change.

This is to be set apart from the open area of the entire ceiling surface. In these, the open joints can be included in the calculation.

Non perforated edges

Different manufacturing processes and staggered perforated surfaces may cause differently pronounced appearances.

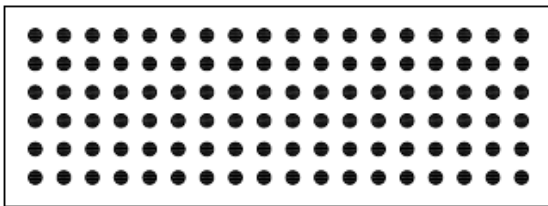

Fig. 62 – Straight row of perforation with unperforated edges

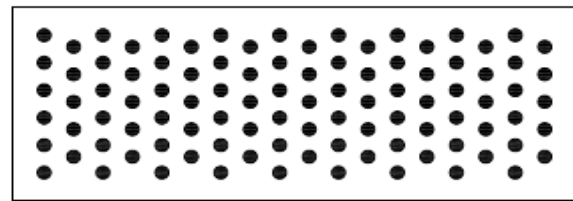

Fig. 63 - Diagonal row of perforation with unperforated edges

Linear panels and open cell ceilings are normally perforated over the narrow side ends. This may result in differently cut holes at these ends.

For tiles, membranes and baffles, the unperforated edge depends on the used perforation pattern and may vary on the long and short sides.

For different membrane lengths and widths, the unperforated edge may vary in size.

The nominal value of the unperforated edge depends on the perforation pattern and the membrane dimensions and is determined by the system manufacturer unless otherwise agreed.

Deviation of the unperforated edge on the long sides	$\pm 0.9 \text{ mm}$
Deviation of the unperforated edge on the short sides	$\pm 0.5 \text{ mm/m}$

7.10.7 Surfaces with protective film

Materials with special surfaces for metal ceiling manufacture are usually supplied by the sheet metal supplier with protective film applied. This is usually not removed by the ceiling manufacturer during manufacture. Unless otherwise agreed upon, such finished products are also supplied with this protective film.

For the production of perforated membranes, lubrication due to the process is necessary.

If no surface coating is applied to the perforated panels by system manufacturers (such as brushed stainless steel, coil coated sheets), they are delivered without post-treatment. In this case, small amounts of lubricant may remain on the surface. Any necessary cleaning work is only possible after the removal of the protective film and has to be arranged on a case by case basis.

Specifications regarding the removal of protective films can be found in the manufacturer's instructions.

8 Test methods

8.1 Geometric properties

Only calibrated instruments with sufficient accuracy are to be used for the measuring.

Digital calipers usually have lower error limits than those with a vernier scale and are therefore to be preferred.

8.1.1 Length and width dimensions

The test can be carried out on a flat surface or with membranes supported on the corners.

The width of linear panels shall be measured at least 150 mm from the edge to eliminate the spring-back influence on the measurement results.

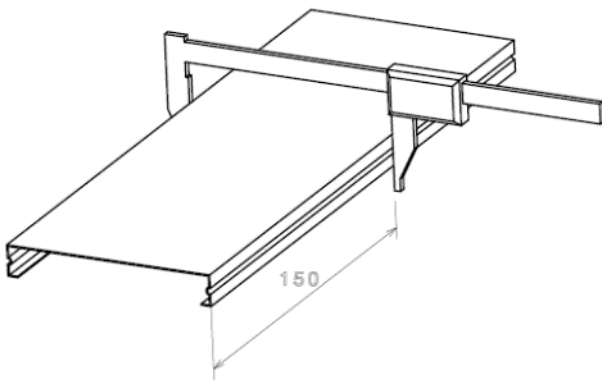

Fig. 64 – Measuring linear panel width

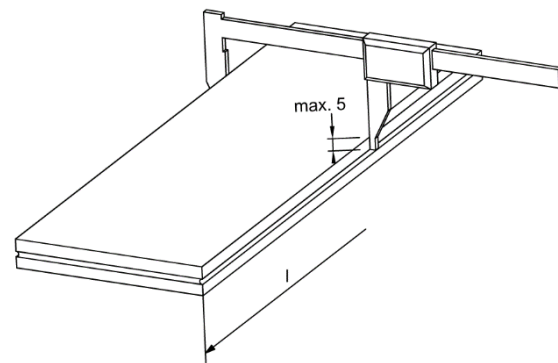

Fig. 65 – Measuring membrane length and width

8.1.2 Upstands

The measuring of linear panels or profiles should always be executed at least 150 mm away from the panel or profile edges in order to reduce the spring-back influence.

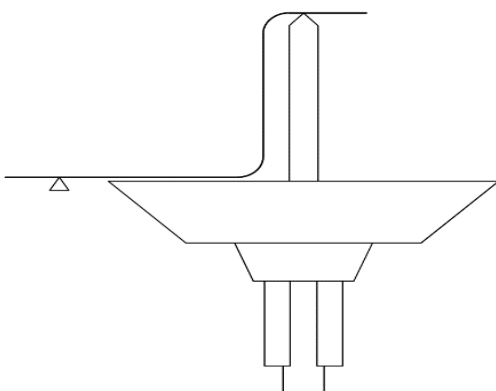

Fig. 66 – Measuring upstand height
Example of Z-upstand

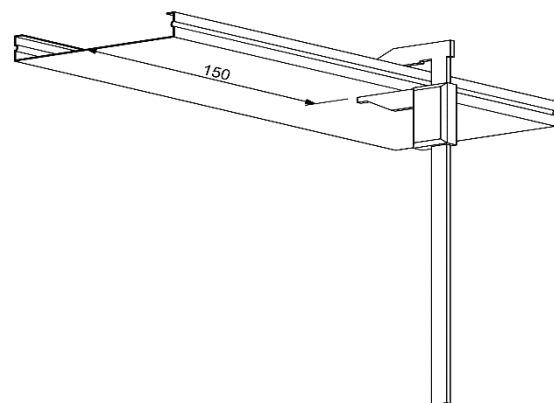

Fig. 67 – Measuring upstand height of a linear panel
Example of C-upstand

8.1.3 Deflection

The deflection of membranes is the maximum deviation in the center of the membrane.

The deflection of linear panels and visible profiles is separated in two different types of deflection: the maximum deviation between the linear panel / profile ends and the width deflection at least 150 mm from the narrow side ends.

This test requires a sufficiently levelled surface e.g. a measuring table or another suitable device.

When measuring the deflection, make sure that the membranes do not warp during the measurement.

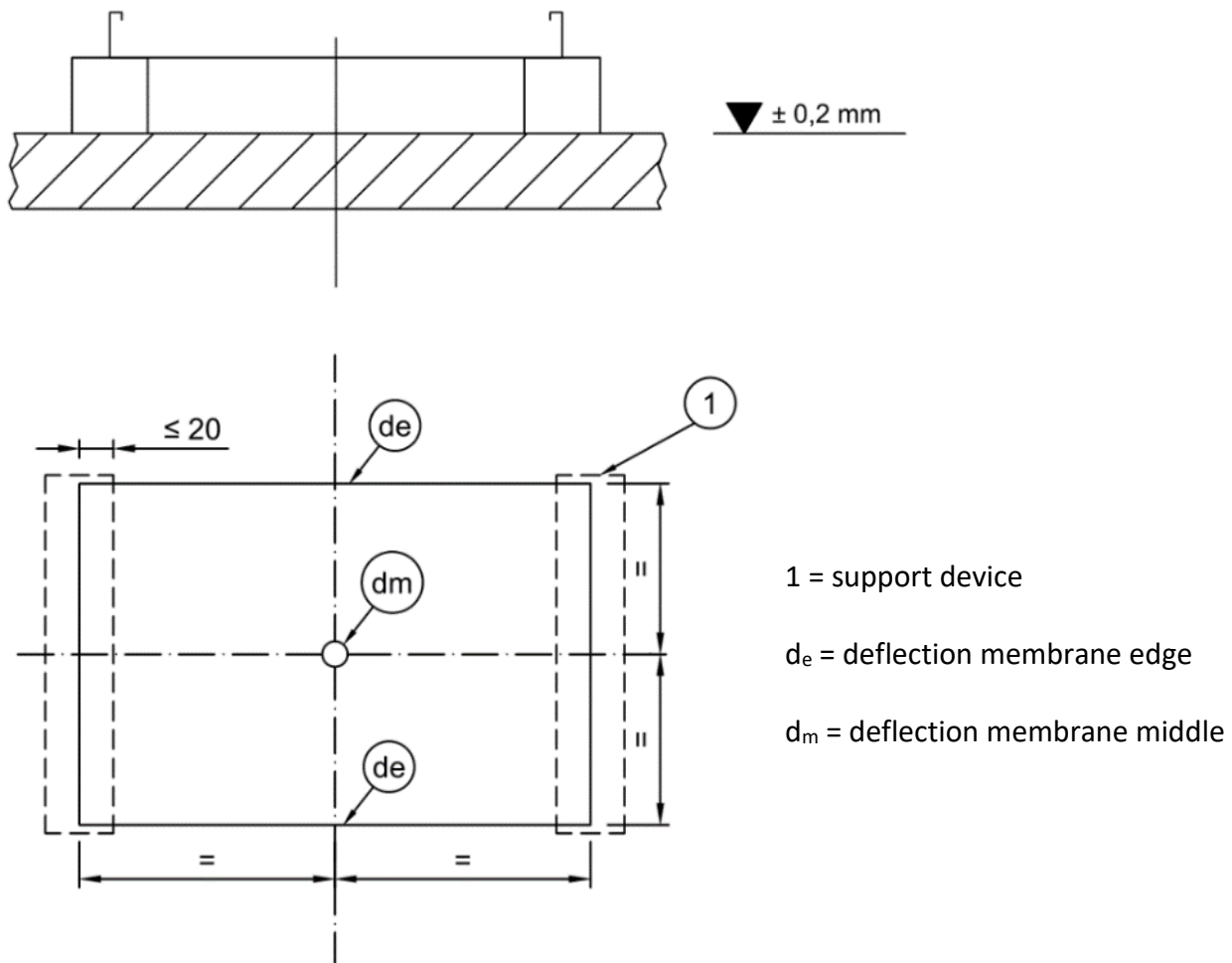

Fig. 68 – Testing the deflection of metal membranes and tiles

The support with a width of up to 20 mm shall be made on the functional edge of the ceiling membrane. If the functional edges are not defined, the two shorter membrane edges shall be used as support.

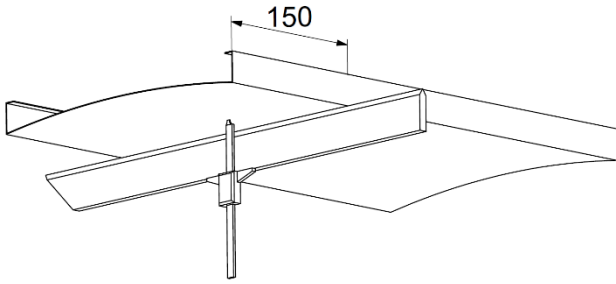

Fig. 69 – Measuring linear panel deflection (concave)

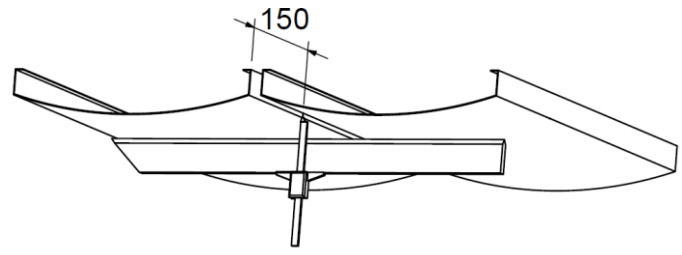

Fig. 70 – Measuring linear panel deflection (convex)

The dimensional check for the deflection and ripple of linear panels (clamped in support profiles) is carried out with the aid of a H-ruler and a precision digital depth gauge.

8.1.4 Camber of linear panels

The camber of linear panels is measured on a completely levelled surface. Two linear panels are laid side-by-side along the entire length, with one panel rotated 180°.

Using a feeler gauge, the distance between the panels is measured in the middle of the panel.

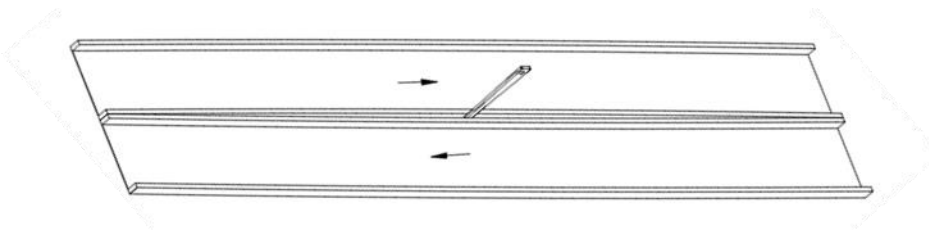

Fig. 71 – Measuring linear panel camber

The measured value for the deviation is (measured value of the feeler gauge) / 2.

Permissible deviation is maximum 0,6 mm/m.

8.1.5 Squareness of membranes

The deviation s from the squareness of the long edge to the short edge shall be determined on a flat surface with a 90° angle stop and a caliper gauge or feeler gauge.

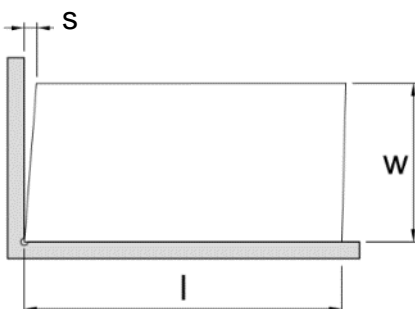

Fig. 72 – Measuring squareness

8.2 Corrosion protection

To demonstrate durability, the following tests are to be carried out on the basis of EN 13964, table 11/12:

Table 24 - relevant tests for corrosion protection requirements

base material	coating ¹⁾	tests		
		coating thickness measurement	visual assessment for defects	adhesion test (cross cut)
standards		EN ISO 2178 EN ISO 2360	---	EN ISO 2409
requirements		min. layer thickness in [μm] according to requirements	no defects, bubbles or inclusions	Gt0 or Gt1
- steel	- galvanising	X	X	---
- steel - galvanised steel	- cathodic-deposition paint	X	X	X
- steel - galvanised steel - aluminium - other	- powder coating - liquid coating	X	X	X
- aluminium	- anodising - cathodic-deposition paint	X	X	X
1) For unlisted coating processes, the relevant tests shall be specified by the manufacturer in each case.				

8.3 Visual assessment of the surface

Metal ceilings shall be classified as surfaces of common visual requirement, for which the following subjective assessment parameters shall be used to assess surface imperfections, other than those specified in 7.10ff:

Table 25 – visual assessment parameters

Observation distance:	≥ 3 m or with room heights < 3 m viewed standing
Viewing angle:	perpendicular to the surface (deviation to perpendicular max ± 30° / no grazing light)
Viewing time:	3 seconds Imperfections shall be detected within 3 seconds
Lighting:	normal diffused light / diffuse daylight
Evaluation:	Crucial for the test is the visual impression through the naked eye without use of technical aids. Markings of alleged defects on the element shall be removed prior to testing
Assessment:	The imperfections shall be recognisable from 2 different viewing angles. Imperfections which are only visible from lateral light for a limited time or due to specific lighting conditions, do not represent a material defect.

Practical assessment criteria and minimum requirements for this are defined, among other things, by the "QIB information sheet 3.1 Visual assessment of organically coated decorative surfaces", published by the Qualitätsgemeinschaft Industriebeschichtung e.V.:

Table 26 – requirements visual quality

Assessment criteria	Minimum requirements	
	per m ²	per 100 cm ²
Craters, bubbles and inclusions	max. 30 pcs ≤ 1,0 mm ² max. 5 pcs ≤ 1,5 mm ²	max. 8 pcs ≤ 1,0 mm ² max. 3 pcs ≤ 1,5 mm ²
Paint runs and accumulations	Permitted and max. threefold coating thickness partially allowed	
Orange peel	without requirements	
Grinding grooves	Cannot be influenced by the coater (is not included in the work scope of the coater); will usually be covered by conventional powder coating systems of a max. roughness of R _{max} < 9 μm (corresponds to grinding paper with a grain size of 180 with orbital sander).	

Continuation of table 26

<p>Substrate quality (e.g. pulling stripes, welding seams, imprints, structures, mechanical damages caused by production, dints, bumps, scratches</p>	<p>Cannot be influenced by the coater.</p> <p>Note: Irregularities may only become apparent after coating.</p>
---	--

Extract from the QIB table Assessment criteria for standard surface class with usual requirements

9 Declaration of performance and CE marking

9.1 Declaration of performance (DoP)

Regulation (EU) No 305/2011 (Construction Products Regulation - CPR) determines harmonized conditions for the marketing of construction products within the EEC.

For all construction products who are either covered by a harmonized standard or for which a European Technical Assessment (ETA) has been issued, the manufacturer shall draw up a declaration of performance (DoP).

With the DoP, the manufacturer takes responsibility for the conformity of the construction product with the declared essential characteristics.

The DoP shall be made available to the customer either in printed or electronic form on its website. When issuing only an electronic version, the manufacturer has to make a clearly recognizable reference on the documents handed over to the client about the source of supply of the DoP.

The DoP shall be provided in the language required by the national provisions of each Member State; For Germany, a German version is required. In other countries an English version is usually recognized.

Table 27 - Example of a DoP for a ceiling substructure component:

Declaration of performance (DoP)	Manufacturers information	Explanation
No.	12345	By the manufacturer freely selectable, but unique number, meaning each number may only be awarded once. Usually each product receives its individual number from the respective manufacturer.
1. Unique identification code of the product-type	4711 Nonius upper part 200mm	Product specification of the manufacturer, e.g. article number and article description
2. Intended use	Suspended ceiling substructure component for indoor installation in buildings	Standard text module according to EN 13964, consisting of one of the 4 following terms: a) Suspended ceiling kit b) Suspended ceiling substructure kit c) Suspended ceiling substructure components d) Suspended ceiling membrane components and the intended use: Internally in buildings
3. Manufacturer	Mustermann AG Musterstreet 1 01234 Musterstadt Tel. 01234/567890 info@mustermann.de www.mustermann.de	Manufacturer is any natural or legal person who owns a construction product either: a) self-produced or b) developed and manufactured by a third party, and markets this product under its own name or brand.

Continuation of Table 27

4. Harmonised standard	EN 13964: 2014	In addition to the number of the harmonized standard, the date of issue (year) shall always be indicated.
5. Notified body/ies	1234 0815	The identification number of the notified body/ies is sufficient. In addition, the name and address of the notified body may also be indicated. All notified bodies involved in the required proof of availability of the product shall be indicated.
6. Declared performance/s	Reaction to fire: Class A1 / AVCP system 3 Load bearing capacity: NPD / AVCP system 3 Resistance to fixings: NPD / AVCP system 3 Durability: NDP / AVCP system 4	List of all essential characteristics according to EN 13964, table ZA.1.3. Only for those essential characteristics for which levels and/or classes are specified in the table above, a value shall be specified (applies here only for the reaction to fire) For all other essential characteristics, it is permissible for the manufacturer to declare "NPD" = No Performance Determined. In addition, indicate the (AVCP - System of Assessment and Verification of consistency of Performance).
7. Manufactures Signature	The performance of the above product is equivalent to the stated performance. The above manufacturer is solely responsible for drawing up the DoP in accordance with the CPR. Signed for and on behalf of the manufacturer of: name / location / date / signature	The DoP shall be signed by a person authorized to legally represent the manufacturer.

The assessment and verification of constancy of performance (AVCP) shall be carried out either by the manufacturer (M) or by a notified body (N) using one of the systems as defined in Delegated Regulation EU No 568/2014 Annex V:

Table 28 - Systems for assessment and verification of consistency of performance (AVCP):

Tasks	System				
	1+	1	2+	3	4
Factory Production Control (FPC)	M	M	M	M	M
Further testing of samples taken in the factory by the manufacturer according to a specified inspection plan	M	M	M		
Initial type testing	N	N	M	N	M
Initial inspection of factory and of FPC	N	N	N		
Continuous surveillance of FPC	N	N	N		
Sample testing of samples taken from the notified body	N				

M = Manufacturer / N = Notified body

9.2 CE-Marking

With the CE marking, the manufacturer, distributor or authorized representative according to EU Regulation declares “that the product complies with the applicable requirements set out in the Community coordination legislation for its affixing”.

The CE-Marking gives no guarantee that components from different manufacturers equipped with CE marking are compatible with each other.

The CE marking shall be clearly visible, legible and permanently affixed directly to the construction product, a label affixed thereto, on the packaging or on the accompanying documents.

The CE marking shall indicate only those essential characteristics for which the manufacturer declares a value in the DoP.

Essential characteristics that the manufacturer declares in the DoP as "NPD" are not to be included in the CE marking.

In opposite to the DoP, there are no requirements in the CPR regarding the language of the CE marking.

	<p>CE marking in accordance with Directive 93/68 / EEC</p>
<p>Mustermann AG Muster street 1 01234 Musterstadt</p>	<p>Manufacturer is any natural or legal person who owns a construction product either: a) self-produced or b) developed and manufactured by a third party, and markets this product under its own name or brand.</p>
<p>16</p>	<p>The last two digits of the year in which the product was first made available on the market. This year need not not be changed, as long as product modifications do not change any essential characteristics of the product.</p>
<p>EN 13964: 2014</p>	<p>Number of the harmonized standard including the year of publication.</p>
<p>Ceilings substructure component Intended use: internally in buildings</p>	<p>Standard text module according to EN 13964, consisting of one of the 4 following terms: a) Suspended ceiling kit b) Substructure kit c) Substructure component d) Membrane component and the intended use: Internally in buildings</p>
<p>Reaction to fire: Class A1</p>	<p>List of those essential characteristics for which a value is declared by the manufacturer in the DoP. Only for those essential properties for which levels and/or classes according to EN 13964, Table ZA.1.3 are specified, a value is mandatory (applies here only for the reaction to fire). Essential characteristics which are declared by the manufacturer in the DoP.with "NPD" need not be listed.</p> <p>According to Commission Decision 96/603 / EC, the reaction to fire of galvanized steel parts is classified without classification in class A ("no contribution to fire").</p>

Fig. 73 - Example of the CE marking of a suspended ceiling substructure component

	CE marking in accordance-with Directive 93/68 / EEC
<p style="text-align: center;"> Mustermann AG Muster street 1 01234 Musterstadt </p>	<p> Manufacturer is any natural or legal person who owns a construction product either: a) self-produced or b) developed and manufactured by a third party, and markets this product under its own name or brand. </p>
<p style="text-align: center;">16</p>	<p> The last two digits of the year in which the product was first made available on the market. This year need not not be changed, as long as product modifications do not change any essential characteristics of the product. </p>
<p style="text-align: center;">EN 13964: 2014</p>	<p> Number of the harmonized standard including the year of publication. </p>
<p style="text-align: center;"> Ceilings substructure component Intended use: internally in buildings </p>	<p> Standard text module according to EN 13964, consisting of one of the 4 following terms: a) Suspended ceiling kit b) Substructure kit c) Substructure component d) Membrane component and the intended use: Internally in buildings </p>
<p> Reaction to fire: Class A2-s1,d0 Load bearing capacity: Class B/No load Durability: Class B </p>	<p> List of those essential characteristics for which a value is declared by the manufacturer in the DoP. Only for those essential characteristics for which levels and/or classes according to EN 13964, Table ZA.1.3 are specified, a value is mandatory. Essential characteristics which are declared by the manufacturer in the DoP with "NPD" need not be listed. The reaction to fire should be tested in accordance with EN 13501-1. The load bearing capacity shall be tested in accordance with EN 13964 point 4.6.2 and classified in accordance with table F.2. The durability is to be classified in one of the classes according to EN 13964 table 9. </p>

Fig. 74 - Example of the CE marking of a suspended ceiling membrane component

10 Environmental Product Declarations

TAIM consistently supports the Environmental Product Declarations (EPD) according to EN 15804 and EN ISO 14025.

TAIM EPDs refer to metal ceiling systems and not just to individual construction products.

The following EPDs currently exist

- Metal ceiling systems made of steel
- Metal ceiling systems made of aluminum
- Metal ceiling systems made of steel as heating and cooling ceilings

These EPDs can be downloaded from the TAIM web server at www.taim.info.

11 Packing, transport and storage

Unless otherwise agreed, packaging shall be as specified by the manufacturer. Transport and storage specifications of the manufacturer are to be observed.

12 Installation

12.1 General

For installation and handling of metal ceilings, qualified specialists with appropriate knowledge shall be employed. The handling of thin metal materials has to be done carefully in order to avoid injuries and damages, if necessary protective gloves have to be worn.

The installation company has to appoint a responsible construction supervisor, who handles and monitors the installation according to the current rules and practices.

The installer has the obligation and full responsibility to provide adequate safety and system compliance to prevent components from falling during and after assembly.

The manufacturer's instructions shall be observed. The installation company has to ensure that no danger or damage to property and in particular danger to life and limb, for persons who are in this room during and after installation exists.

The structural conditions given by the building designer, such as facade movements, building movements and expansion joints are to be considered.

12.2 Installation instructions

12.2.1 Requirement of structural parts

Only components approved by the manufacturer shall be used. The substructure has to match to the metal ceiling system and need to have sufficient longitudinal and lateral stability.

12.2.2 Flatness tolerances

For the installation of visible substructures, ceiling materials and perimeter trims, the allowable deviation from flatness is ± 2 mm per meter length, but not more than 5 mm for a length of 5 meters, measured horizontally at the point of the hanger in each direction. Permissible deflections of the membrane components are not included in the flatness tolerances and shall be considered additionally.

12.2.3 Installation sequence

In order to ensure the flatness of the installation, the perimeter trim shall first be fixed to the perimeter walls at the correct suspension height. When there is no wall connection, the flatness has to be ensured by suitable measuring points.

12.2.4 Alignment

The visible substructures and supporting profiles running parallel with each other shall be aligned in such a way that the modules are in precise alignment with each other (if possible by using a laser or line). Make sure that the modules are aligned behind support profile splices.

12.2.5 Absence of twisting

The suspension of the supporting profiles shall result in torsion-free and levelled conditions whilst at the same time being tight.

12.2.6 Alignment of the substructure

Metal ceilings and their usually large element lengths make careful installation and alignment of the substructure (supporting profiles) necessary. This applies in particular to metal panels, for which a transverse bracing of the support grid is usually left out.

12.2.7 Built-ins, built-ons, add-ons

The building planner has the overall responsibility for installed components, in particular the type, location, selection and basic system conformity. The integration of the components shall be made in accordance with the specifications of the ceiling manufacturer and the manufacturer of the components. All work in this context are additional measures and has to be agreed upon separately. The connection of e.g. electrical components has to be clarified in each and every case and according to the specifications of the manufacturer.

12.3 Surfaces

12.3.1 Batch dependency

In order to avoid colour and gloss deviations between different coating batches, the entire material for the relevant ceiling surface has to be ordered in one order.

If this is not possible, a mixing of the partial deliveries during installation has to be avoided.

12.3.2 Directionality

The production process for metal ceilings is generally directionally bounded via the rolling / edging technique up to and including the painting process. If this has an influence on the installation, it shall be specified by the manufacturer.

In order to avoid optical deviations, all membrane components should be installed in the same direction. This direction is determined either by a marking of the membrane components or by references on the packaging by the manufacturer.

12.4 Special features of linear panels

12.4.1 Flatness at the perimeter

Due to the manufacturing process, it can happen that factory- and on-site cutting of the thin metal strips can cause a flatness deviation on the perimeter trim, which is unavoidable and state of the art.

Special requirements for the linear panel flatness at the perimeter have to be considered by the contractor.

12.4.2 Linear panel connections

Connections of perforated linear panels shall be executed with longitudinal connectors (panel splices).

A slight visual impairment of the uniformity of the ceiling appearance at the connection is technically inevitable, since perforated linear panels have no unperforated panel ends.

12.4.3 Squareness, thermal expansion, additional loads, special areas

When installing linear panels, the absolute perpendicularity of the linear panels in relation to the support profiles shall be ensured at all points.

When using construction profiles as well as membrane components, the thermal expansion of aluminum shall be taken into account. This is 0.024 mm per meter profile length at a temperature difference of 1°C. Aluminum profiles are manufactured at a normal temperature of +18°C. The length tolerances of the TMMC do not take into account length deviations due to thermal expansion.

Additionally installed components and additional loads shall be suspended separately. Any attachments to the ceiling system shall be agreed upon in advance with the manufacturer. In particular, installations of cooling and fire protection ceilings are to be carried out by qualified specialists who have appropriate knowledge of the systems and the required properties.

For special applications, such as in the kitchen area, in the outdoors, in damp- and cleanrooms and in rooms with requirements for fire protection, sound insulation, ball impact safety, the substructure and the membrane quality and their installation shall be specified separately.

The manufacturer's instructions are to be observed.

The transport instructions of the manufacturer as well as the information for professional stacking and dry storage shall be strictly observed.

13 Maintenance and operation

13.1 Service life requirements (maintenance)

Metal ceilings produced according to TMMC are easy to maintain and durable.

They shall keep their performance characteristics when exposed to the intended conditions, maintained as recommended by the manufacturer, and not be harmfully treated during their service life.

The requirements for the warranty, especially regarding the period of validity, are independent of this.

The following information regarding durability and maintenance shall be taken into account:

1. Cleaning recommendations apply to the instructions listed under 13.2
Any other information shall be stated by the manufacturer.
2. Metal ceilings are easy to maintain, but from time to time it is advisable to check for:
 - Changes, new installed components, e.g. lights etc.
 - Subsidence in partial areas
 - Deformations

If changes emerge, they have to be followed up.

The loosening and falldown of ceiling parts has to be excluded in principle.

These minimum requirements shall be met so that the ceiling can meet the required properties during the service life.

13.2 Cleaning

Cleaning recommendations for metal ceiling membranes:

The possible surfaces are very diverse and go from normal white over metallic to fluorescent colours and anodised surfaces.

Each surface may require its own cleaning method; the cleaning recommendation given here can be applied to all common systems.

However, it is always necessary to consult the manufacturer in order to prevent damage.

Possibilities:

- Use only clean water, if necessary with low additive of neutral or slightly alkaline detergent.
- With the help of soft, non-abrasive cloths, a mechanical cleaning effect can additionally be achieved. Strong rubbing is to be avoided.
- Do not use steam or high pressure cleaners.
- Do not use coarse, abrasive products.
- Use only soft cloths or industrial cotton for cleaning.
- Do not use acidic or strongly alkaline detergents and surfactants.
- Do not use organic solvents containing esters, ketones, alcohols, aromatics, glycol ethers, halogenated hydrocarbons or similar.
- Do not use detergents of unknown composition.
- The removal of greasy, oily or sooty substances can be carried out with aromatic free petrol based hydrocarbons.
- Residues of adhesives, silicone rubber or adhesive tapes can also be removed in this way. Important is their immediate removal. Preliminary tests on non-visible surfaces are mandatory!

14 Recycling

Metallic materials in metal ceiling systems can be returned to the recycling cycle.

Metal ceilings are made of high quality, durable materials. Galvanized sheet steel and aluminum are predominantly used for the systems. Attention is paid to conserving resources right from the design stage.

The material thicknesses used for the ceiling panels are usually between 0.5 and 1.5 mm for galvanized sheet steel and 0.5 to 3.0 mm for aluminum. Always exactly as much as is necessary to achieve the diverse requirements.

The modular structure of the systems makes it easy to dismantle and separate the recyclables according to type. The metals used, steel, aluminum and copper, are 100% recyclable.

The recycling process for scrap metal has been established and exists locally for decades.

The thin coloring surface of metal ceiling systems is made of organic and environmentally friendly material that burns when melted. It is similar with the acoustic fleece, which in combination with the perforation ensures the very good sound-absorbing properties of the metal ceiling systems. Part of the fleece is already removed during the mechanical preliminary processes (shredding, pressing). When melted, the remaining organic portion burns and the glass fiber portion floats up as "slag."

In standard systems, less than 5% of the weight is made up of such impurities.

The dismantled metal ceiling systems are returned to the established recycling process via regional scrap recyclers.

There is no need for landfilling, as is the case with other ceiling materials.

Metals are valuable materials!

Additional information is provided by the system manufacturers and the respective EPDs.

15 National annex Germany

15.1 Smoke leakage

In Germany, the “Muster- und Landesbauordnungen“ stipulate that "structural systems ... are to be constructed ... that ... the spread of fire and smoke ... is prevented ...".

The test procedure for the fire resistance of metal ceilings is established. There is no separate test of smoke leakage here either.

The fire integrity of stand-alone suspended metal ceilings as fire protection ceilings (suspended ceiling alone) is an essential part of the test procedure. If the design fails at this point, the test is deemed to have been failed.

It is therefore recommended to consider metal ceilings that have been appropriately tested and classified as stand-alone suspended metal ceilings as fire protection ceilings (suspended ceiling alone) as smoke-tight in the sense of the building authority requirements.

According to this, in Germany “fire-resistant suspended ceilings are stand-alone metal ceilings in accordance with VVTB “(Verwaltungsvorschrift für technische Baubestimmungen, C 4.1) as types of construction that are regulated by a “allgemeines bauaufsichtliches Prüfzeugnis“(abP, national proof of usability).

16 Technical terms English - German

Table 26 – Technical terms English - German

Term English	Term German
(acoustic) tissue	(Akustik-)Vlies
building element	Bauteil / Bauart
built-in installations	Einbauten
built-on fixtures	Aufbauten
certificate of usability	Verwendbarkeitsnachweis
classification report	Klassifizierungsbericht
clip-in system	Klemmsystem
coating	Beschichtung
Connection / joint	Stoß
construction product	Bauprodukt
cross post cap	Kreuzbandraster
Custom-fit membrane	Passplatte
cutout / cut-out	(Platten-)Ausschnitt
double-walled baffle	doppelwandige Lamelle
expanded metal	Streckmetall
functional upstand	Funktionskante
heated and chilled ceiling	Heiz- & Kühldecke
inlay	Einlage
inspection hatch	Revisionsbauteil
lay-on	Auflage
linear panel	Paneel
liquid paint	Naßlackierung
membrane	Deckenplatte, Decklage
perimeter trim	Randprofil
post cap	Bandraster
reaction to fire	Brandverhalten
fire resistance	Feuerwiderstand
single-walled baffle	einwandige Lamelle
smoke leakage	Rauchdichtheit
stiffening / bracing	Aussteifung
support profile	Tragprofil
swing-down system	(Ab-)Klappsysteem
tile ceiling system / cassette ceiling	Kassettendecke
upstand / turn-up	Aufkantung

17 Revision history

This edition differs from TMMC January 2021 as follows:

Page	Topic	Changes
9	3	Update normative references
41	6.9	Definition durability range revised
60ff	7.9	Complete revision of the chapter corrosion protection
86f	14	Update recyclability of metal



www.taim.info